

Test Code : CSB (Short Answer Type) 2019

Junior Research Fellowship (JRF) in Computer Science

Sample Questions

Note that all questions in the sample set are not at the same level of difficulty, and may not carry equal marks in an examination.

GROUP A

A1. A king's minter keeps mn coins in n boxes each containing m coins. Each box contains 2 false coins out of m coins. The king suspects the minter and randomly draws 1 coin from each of the n boxes and has these tested. What is the probability that the minter's dishonest actions go undetected?

A2. Consider the pseudo-code given below.

Input: Integers b and c .

1. $a_0 \leftarrow \max(b, c)$, $a_1 \leftarrow \min(b, c)$.
2. $i \leftarrow 1$.
3. Divide a_{i-1} by a_i . Let q_i be the quotient and r_i be the remainder.
4. If $r_i = 0$, then go to Step 8.
5. $a_{i+1} \leftarrow a_{i-1} - q_i * a_i$.
6. $i \leftarrow i + 1$.
7. Go to Step 3.
8. Print a_i .

What is the output of the above algorithm when $b = 28$ and $c = 20$?
What is the mathematical relation between the output a_i and the two inputs b and c ?

A3. Consider the sequence $a_n = a_{n-1} a_{n-2} + n$ for $n \geq 2$, with $a_0 = 1$ and $a_1 = 1$. Is a_{2011} odd? Justify your answer.

- A4. The integers 1, 2, 3, 4 and 5 are to be inserted into an empty stack using the following sequence of PUSH() operations:

PUSH(1) PUSH(2) PUSH(3) PUSH(4) PUSH(5)

Assume that POP() removes an element from the stack and outputs the same. Which of the following output sequences can be generated by inserting suitable POP() operations into the above sequence of PUSH() operations? Justify your answer.

- (a) 5 4 3 2 1
- (b) 1 2 3 4 5
- (c) 3 2 1 4 5
- (d) 5 4 1 2 3.

- A5. Derive an expression for the maximum number of regions that can be formed within a circle by drawing n chords.

- A6. Given $A = \{1, 2, 3, \dots, 70\}$, show that for any six elements a_1, a_2, a_3, a_4, a_5 and a_6 belonging to A , there exists one pair a_i and a_j for which $|a_i - a_j| \leq 14$ ($i \neq j$).

- A7. The function RAND() returns a positive integer from the uniform distribution lying between 1 and 100 (including both 1 and 100). Write an algorithm (in pseudo-code) using the given function RAND() to return a number from the binomial distribution with parameters $(100, 1/4)$.

- A8. Calculate how many integers in the set $\{1, 2, 3, \dots, 1000\}$ are not divisible by 2, 5, or 11.

- A9. Let M be a 4-digit positive integer. Let N be the 4-digit integer obtained by writing the digits of M in reverse order. If $N = 4M$, then find M . Justify your answer.

- A10. Consider all the permutations of the digits 1, 2, ..., 9. Find the number of permutations each of which satisfies *all* of the following:

- the sum of the digits lying between 1 and 2 (including 1 and 2) is 12,

- the sum of the digits lying between 2 and 3 (including 2 and 3) is 23,
- the sum of the digits lying between 3 and 4 (including 3 and 4) is 34, and
- the sum of the digits lying between 4 and 5 (including 4 and 5) is 45.

A11. State, with justification, which of the following expressions f , g and h , define valid real-valued functions over the set of positive rational numbers. We denote a rational number by m/n , where m and n are positive integers.

- (a) $f(m/n) = 2^m - 2^n$.
 (b) $g(m/n) = \log m - \log n$.
 (c) $h(m/n) = (m^2 - n^2)/(mn)$.

A12. Given a function $f : A \rightarrow A$, an element $x \in A$ is said to be a fixed point of f if and only if $f(x) = x$. Let $f : \{1, 2, \dots, 100\} \rightarrow \{1, 2, \dots, 100\}$ be a function. For all $S \subseteq \{1, 2, \dots, 100\}$, suppose a procedure $\text{FIXED}(S)$ can determine whether the function f has at least one fixed point in S or not. Define a strategy to determine whether the function f has at least two fixed points by executing the procedure FIXED at most 15 times.

A13. There are n students in a class. The students have formed k committees. Each committee consists of more than half of the students. Show that there is at least one student who is a member of more than half of the committees.

A14. Let $D = \{d_1, d_2, \dots, d_k\}$ be the set of distinct divisors of a positive integer n (D includes 1 and n). Show that

$$\sum_{i=1}^k \sin^{-1} \sqrt{\log_n d_i} = \frac{\pi}{4} \times k.$$

HINT: $\sin^{-1} x + \sin^{-1} \sqrt{1 - x^2} = \frac{\pi}{2}$

- A15. Give a strategy to sort four distinct integers a, b, c, d in increasing order that minimizes the number of pairwise comparisons needed to sort any permutation of a, b, c, d .
- A16. An $n \times n$ matrix is said to be *tridiagonal* if its entries a_{ij} are zero except when $|i - j| \leq 1$ for $1 \leq i, j \leq n$. Note that only $3n - 2$ entries of a tridiagonal matrix are non-zero. Thus, an array L of size $3n - 2$ is sufficient to store a tridiagonal matrix. Given i, j , write pseudo-code to
- store a_{ij} in L , and
 - get the value of a_{ij} stored in L .
- A17. Consider an $m \times n$ integer grid. A *path* from the lower left corner at $(0, 0)$ to the grid point (m, n) can use three kinds of steps, namely (i) $(p, q) \rightarrow (p + 1, q)$ (horizontal), (ii) $(p, q) \rightarrow (p, q + 1)$ (vertical), or (iii) $(p, q) \rightarrow (p + 1, q + 1)$ (diagonal). Derive an expression in terms of m and n for $D_{m,n}$, the number of such distinct paths.
- A18. The numbers $1, 2, \dots, 10$ are circularly arranged. Show that there are always three adjacent numbers whose sum is at least 17, irrespective of the arrangement.
- A19. Consider six distinct points in a plane. Let m and M denote respectively the minimum and the maximum distance between any pair of points. Show that $M/m \geq \sqrt{3}$.
- A20. Consider the following intervals on the real line:

$$\begin{aligned} A_1 &= (13.3, 18.3) & A_3 &= (8.3, 23.3) - A_1 \cup A_2 \\ A_2 &= (10.8, 20.8) - A_1 & A_4 &= (5.8, 25.8) - A_1 \cup A_2 \cup A_3 \end{aligned}$$

where $(a, b) = \{x : a < x < b\}$.

Write pseudo-code that finds the interval to which a given input $x \in (5.8, 25.8)$ belongs, i.e., your pseudo-code should calculate $i \in \{1, 2, 3, 4\}$ such that $x \in A_i$. Your method should not use any comparison operation.

- A21. A group of 15 boys plucked a total of 100 apples. Prove that two of those boys plucked the same number of apples.
- A22. How many 0's are there at the end of $50!$?
- A23. Suppose X is a set such that for every function $f : X \rightarrow X$, f is one-to-one if and only if f is onto. Show that every one-to-one function $f : P(P(X)) \rightarrow P(P(X))$ is onto, where $P(A)$ denotes the set of all subsets of a set A .
- A24. Given an array $A = \{a_1, a_2, \dots, a_n\}$ of unsorted distinct integers, write a program in *pseudo-code* for the following problem: given an integer u , arrange the elements of the array A such that all the elements in A which are less than or equal to u are at the beginning of the array, and the elements which are greater than u are at the end of the array. You may use at most 5 extra variables apart from the array A .
- A25. The vertices of a triangle T are given. For an arbitrary point P in the plane, give an algorithm to test if P belongs to the interior of T . (The interior of T does not include its edges).
- A26. Find the value of $\sum ij$, where the summation is over all integers i and j such that $1 \leq i < j \leq 10$.
- A27. Let $S = \{x \in \mathbb{R} : 1 \leq |x| \leq 100\}$. Find all subsets M of S such that for all x, y in M , their product xy is also in M .
- A28. Let us consider the following 2-person game: the players alternately choose a number. The first player starts with a number between 1 and 10, and the players then pick up a number within the next ten of the number that his opponent has chosen earlier. The player who is able to select the number 100 first, wins the game. Can the first player pick up a number between 1 and 10 such that whatever may be the strategy of his opponent, the first player will be able to reach 100 first?

GROUP B
COMPUTER SCIENCE

- C1. (a) Write the smallest real number greater than 6.25 that can be represented in the IEEE-754 single precision format (32-bit word with 1 sign bit and 8-bit exponent).
- (b) Convert the sign-magnitude number **10011011** into a 16-bit 2's complement binary number.
- (c) The CPU of a machine is requesting the following sequence of memory accesses given as word addresses: 1, 4, 8, 5, 20, 17, 19, 56. Assuming a direct-mapped cache with 8 one-word blocks, that is initially empty, trace the content of the cache for the above sequence.
- C2. A machine \mathcal{M} has the following *five* pipeline stages; their respective time requirements in nanoseconds (ns) are given within parentheses:
 F -stage — instruction fetch (9 ns),
 D -stage — instruction decode and register fetch (3 ns),
 X -stage — execute/address calculation (7 ns),
 M -stage — memory access (9 ns),
 W -stage — write back to a register (2 ns).
Assume that for each stage, the pipeline overhead is 1 ns. A program P having 100 machine instructions runs on \mathcal{M} , where every 3rd instruction needs a 1-cycle stall before the X -stage. Calculate the CPU time in micro-seconds for completing P .
- C3. The CPU of a computer has a ripple-carry implementation of a 2's complement adder that takes two 8-bit integers $A = a_7a_6 \dots a_0$ and $B = b_7b_6 \dots b_0$ as inputs, and produces a sum $S = s_7s_6 \dots s_0$, where $a_i, b_i, c_i \in \{0, 1\}$ for $(0 \leq i \leq 7)$.
Let $A = 1001\ 1001$ and $B = 1000\ 0110$. What will be the output S of the adder? How will the value of S be interpreted by the machine?
- C4. Add the following two floating point numbers A and B given in IEEE-754 single precision format and show the sum S in the same format.
 A : 0000011000100 0000 0000000000000001
 B : 1000011000100 0000 0000000000000001

C5. Draw a complete binary tree T with $(N - 1)$ nodes where $N = 2^n$. Suppose each node in T is a processor and each edge of T is a physical link between two processors through which they can communicate. Given M arrays $A_i = \{e_{1i}, e_{2i}, \dots, e_{Ni}\}$ for $1 \leq i \leq M$, develop an algorithm for the given architecture to compute the sum of each array $SUM_i = \sum_{j=1}^N e_{ji}$ for all i in $O(\log N + M)$ time.

C6. Let C denote a logic block that is capable of comparing two 4-bit 2's complement numbers $A (a_3, a_2, a_1, a_0)$ and $B (b_3, b_2, b_1, b_0)$, where $a_i, b_i \in \{0, 1\}$ for $i = 0, 1, 2, 3$. The circuit C has eight input lines $a_3, a_2, a_1, a_0, b_3, b_2, b_1, b_0$, and three output lines E, L, G (Equal: E ; Less than: L ; Greater than: G). For example, if $A > B$, then the outputs should be $E = 0, L = 0$, and $G = 1$.

Write the Boolean equations for the three outputs E, L , and G .

C7. (a) A Boolean function f is said to be positive unate if f can be expressed in a form where all the variables appear in uncomplimented form, and only the AND and OR Boolean operators are used. For example, the function $g_1 = X_1X_2 + X_2X_3$ is positive unate but $g_2 = X_1X_2 + \bar{X}_2X_3$ is not. Consider the following circuit and determine which of the two functions f_1 and f_2 are positive unate.

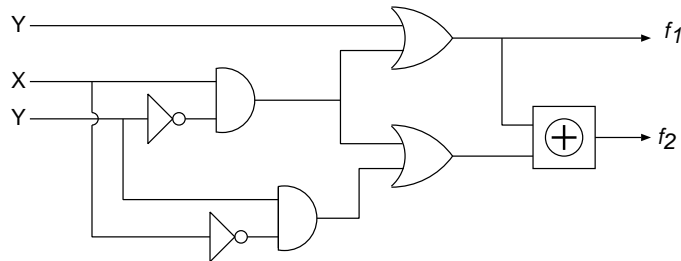

(b) Consider a machine with four registers (one of which is the accumulator A) and the following instruction set.

- LOAD R and STORE R are indirect memory operations that load and store using the address stored in the register R. Thus, LOAD R loads the contents of memory[R] into A and STORE R stores the contents of A in memory[R].
- MOV R1 R2 copies the contents of register R1 into register R2.

- ADD R and SUB R operate on the accumulator and one other register R, such that $A = A \text{ op } R$.
- LDC n stores the 7-bit constant n in the accumulator.
- BRA, BZ, and BNE are branch instructions, each taking a 5-bit offset.

Design an instruction encoding scheme that allows each of the above instructions (along with operands) to be encoded in 8 bits.

- C8. (a) In a Buddy memory allocation system, a process is allocated an amount of memory whose size is the smallest power of 2 that is greater than or equal to the amount requested by the process. A system using buddy memory allocation has 1MB memory. For a given sequence of nine processes, their respective memory requirements in KB are: 50, 150, 90, 130, 70, 80, 120, 180, 68.
- Illustrate with an allocation diagram to justify whether all the requests, in the given order, can be complied with. Assume that memory once allocated to a process is no longer available during the entire span of the above sequence.
 - Calculate the total memory wasted due to fragmentation in your memory allocation by the above scheme.
- (b) Two processes P_1 and P_2 have a common shared variable `count`. While P_1 increments it, P_2 decrements it. Given that R0 is a register, the corresponding assembly language codes are:

P_1 : <code>count++</code>			P_2 : <code>count--</code>		
MOV	<code>count</code>	R0	MOV	<code>count</code>	R0
ADD	<code>#1</code>	R0	SUB	<code>#1</code>	R0
MOV	R0	<code>count</code>	MOV	R0	<code>count</code>

Give an example to justify whether a race condition may occur if P_1 and P_2 are executed concurrently.

- C9. The access time of a cache memory is 100 ns and that of main memory is 1000 ns. It is estimated that 80% of the memory requests are for read and the remaining 20% are for write. The hit ratio for read access is 0:9. A write through procedure is used.
- What is the average access time of the system considering only memory read cycles?
 - What is the average access time of the system considering both read and write requests?

- C10. Consider the following solution to the critical section problem for two processes. The two processes, P_0 and P_1 , share the following variables:

```
char flag[2] = {0,0};
char turn = 0;
```

The program below is for process P_i ($i = 0$ or 1) with process P_j ($j = 1$ or 0) being the other one.

```
do {
    flag[i] = 1;
    while (flag[j])
        if (turn == j) {
            flag[i] = 0;
            while (turn == j) {};
        }
    ...
    CRITICAL SECTION
    ...
    turn = j;
    flag[i] = 0;
    ...
    REMAINDER SECTION
    ...
} while (1);
```

Does this solution satisfy the mutual exclusion, progress and bounded waiting properties?

- C11. Suppose that an operating system provides two functions, `block()` which puts the calling process on the blocked queue, and `wakeup(P)` which moves process P to the runnable queue if it is currently on the blocked queue (otherwise, its behaviour is unpredictable).

Consider two processes A and B running the code given below. The intended behaviour of the code is to have A and B run forever, alternately printing their names on the screen.

```

void A()
{ while(1) {
    block();
    printf("A");
    wakeup(B);
}
}

void B()
{ while(1) {
    printf("B");
    wakeup(A);
    block();
}
}

```

- (a) Construct a scenario in which the intended behaviour would not be observed.
- (b) Redesign the code using semaphore(s) so that it works correctly. You should show the initialisation of the semaphore(s), and the calls to `wait()` and `signal()` made by *A* and *B*.

C12. A system has 4 processes A, B, C, D and 5 allocatable resources R_1, R_2, R_3, R_4, R_5 . The maximum resource requirement for each process and its current allocation are as follows.

Process	Maximum	Allocation
	R_1, R_2, R_3, R_4, R_5	R_1, R_2, R_3, R_4, R_5
A	1, 1, 2, 1, 3	1, 0, 2, 1, 1
B	2, 2, 2, 1, 0	2, 0, 1, 1, 0
C	2, 1, 3, 1, 0	1, 1, 0, 1, 0
D	1, 1, 2, 2, 1	1, 1, 1, 1, 0

Suppose the currently available count of resources is given by 0, 0, X , 1, 1. What is the minimum value of X for which this is a safe state? Justify your answer.

C13. There are n students standing in a line. The students have to rearrange themselves in ascending order of their roll numbers. This rearrangement must be accomplished only by successive swapping of adjacent students.

- (i) Design an algorithm for this purpose that minimises the number of swaps required.
- (ii) Derive an expression for the number of swaps needed by your algorithm in the worst case.

C14. The *C* function `divby3` given below is intended to check whether a given number is divisible by 3. It assumes that the argument `number`

is a string containing the decimal representation of a positive integer, and returns 1 or 0 depending on whether the integer is divisible by 3 or not.

```
int divby3(char *number)
{
    int sum = 0;
    while (*number != '\0') {
        sum += *number - '0';
        number++;
    }
    return (sum % 3) ? 0 : 1;
}
```

Assume that a variable of type `int` is stored using 4 bytes and the decimal representations of arbitrarily large positive integers can be passed as arguments to `divby3`.

- (a) Show that the given function does not work correctly for some integers larger than 10^{10^9} .
- (b) Modify the above function so that it works as intended for all positive integers.

NOTE: The smaller the number of ALU operations used by your function, the more marks you will get.

- C15. Consider the *fast square and multiply algorithm* to calculate $x^y \bmod N$ as given below, where x, y, N are positive integers and $1 \leq x, y < N$.

```

Input:  $x, y, N$ 
Output:  $x^y \bmod N$ 
1  $z = y, u = 1, v = x;$ 
2 while  $z > 0$  do
3   | if  $z \equiv 1 \pmod{2}$  then
4   |   |  $u = uv \bmod N;$ 
5   |   end
6   |  $v = v^2 \bmod N; z = \lfloor \frac{z}{2} \rfloor;$ 
7   end
8 return  $u.$ 

```

- (a) Write a C function to implement the algorithm. Your function should take three arguments x , y and N , and return the value $x^y \bmod N$, all of which are of type `unsigned long long` (i.e., 64-bit unsigned integers).
- (b) Discuss whether your program works perfectly for all possible input combinations.
- (c) What is the time complexity of the algorithm (not your C implementation) in terms of N ? [Note that N can be a very large integer, e.g., more than 512 bits. Assume that the time complexity of modular multiplication is $O(\log^2 N)$, when the positive integers involved are less than N .]
- C16. (a) Let $R = (A, B, C, D, E, F)$ be a schema with the set $F = \{A \rightarrow BC, CD \rightarrow E, B \rightarrow D, E \rightarrow A\}$ of functional dependencies. Suppose R is decomposed into two schemata $R_1 = (A, B, C)$ and $R_2 = (A, D, E, F)$
- Is this decomposition loss-less? Justify.
 - Is this decomposition dependency preserving? Justify.
 - Identify all the candidate keys for R .
 - Decompose R into normalized sets of relations using 3NF.
 - If a new dependency $A \twoheadrightarrow F$ (multi-valued dependency) is introduced, what would be the new set of normalized relations?
- (b) Consider the relations $r_1(A, B, C)$, $r_2(C, D, E)$ and $r_3(E, F)$. Assume that the set of all attributes constitutes the primary keys of these relations, rather than the individual ones. Let $V(C, r_1)$ be 500, $V(C, r_2)$ be 1000, $V(E, r_2)$ be 50, and $V(E, r_3)$ be 150, where $V(X, r)$ denotes the number of distinct values that appear in relation r for attribute X . If r_1 has 1000 tuples, r_2 has 1500 tuples, and r_3 has 750 tuples, then give the ordering of the natural join $r_1 \bowtie r_2 \bowtie r_3$ for its efficient computation. Justify your answer.
- C17. A block of bits with n rows and m columns uses horizontal and vertical parity bits for error detection. If exactly 4 bits are in error during transmission, derive an expression for the probability that the error will be detected.

C18. A school database maintains the following relations for its students, teachers and subjects:

- Student(st_name, st_address, class, section, roll_no, regn_no)
- Teacher(t_name, t_address, tel_no)
- Subject(s_name, t_name, text_book, class)

Consider the following constraints on the existing data.

- A student after admission to the school is assigned with a unique regn_no. However, a student also gets a roll_no that starts from 1 for each class and section. A class can have many sections and a student is placed in only one class and section as expected in a school.
 - In the school a teacher's name (t_name) has been found to be unique. However, more than one teacher may stay at the same address and the tel_no is a land line connection where an address will have only one such telephone.
 - A subject name (s_name) is unique but the same subject may be taught in many classes (for example, History may be taught in many classes with different contents but s_name remains the same). Every subject has a set of standard text_books for a class and there may be more than one teacher who can teach the subject. Any teacher may use any of the standard text books to teach a subject.
- (a) Considering the above constraints, identify the functional /multivalued dependencies present and normalize the relations.
- (b) Using the normalized set of relations answer the following query using relational algebra or SQL: List all the teachers (t_name) who can teach History in Class V and reside in "Baranagar" (name of a locality). Consider that any address offers a locality name.

- C19. A program P consisting of 1000 instructions is run on a machine at 1 GHz clock frequency. The fraction of floating point (FP) instructions is 25%. The average number of clock-cycles per instruction (CPI) for FP operations is 4.0 and that for all other instructions is 1.0.
- Calculate the average CPI for the overall program P .
 - Compute the execution time needed by P in seconds.
- C20. Consider a 100Mbps token ring network with 10 stations having a ring latency of $50 \mu\text{s}$ (the time taken by a token to make one complete rotation around the network when none of the stations is active). A station is allowed to transmit data when it receives the token, and it releases the token immediately after transmission. The maximum allowed holding time for a token (THT) is $200 \mu\text{s}$.
- Express the maximum efficiency of this network when only a single station is active in the network.
 - Find an upper bound on the token rotation time when all stations are active.
 - Calculate the maximum throughput rate that one host can achieve in the network.
- C21. (a) Station A is sending data to station B over a full duplex error free channel. A sliding window protocol is being used for flow control. The send and receive window sizes are 6 frames each. Each frame is 1200 bytes long and the transmission time for such a frame is $70 \mu\text{s}$. Acknowledgment frames sent by B to A are very small and require negligible transmission time. The propagation delay over the link is $300 \mu\text{s}$. What is the maximum achievable throughput in this communication?
- (b) Consider a large number of hosts connected through a shared communication channel. The hosts transmit whenever they have any data. However, if two data packets try to occupy the channel at the same time, there will be a collision and both will be garbled. The hosts retransmit these packets that suffered collisions. Assume that the generation of new packets by a host is a Poisson process and is independent of other hosts. The total number of transmissions (old and new packets combined) per packet time follows Poisson distribution with mean 2.0 packets per packet

time. Compute the throughput of the channel. (Packet time is the amount of time needed to transmit a packet.)

- C22. (a) Construct a finite state machine that accepts all the binary strings in which the number of 1's and number of 0's are divisible by 3 and 2, respectively.
- (b) Describe the language recognized by the following machine.

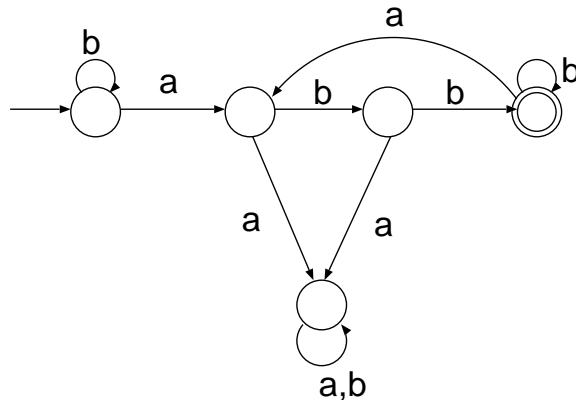

- (c) Consider the grammar $E \rightarrow E + n | E \times n | n$. For a sentence $n + n \times n$, find the handles in the right sentential form of the reductions.

C23. Design a Turing machine that recognizes the unary language consisting of all strings of 0's whose length is a power of 2, i.e., $L = \{0^{2^n} | n \geq 0\}$.

- C24. (a) Write a context-free grammar for the language consisting of all strings over $\{a, b\}$ in which the number of a 's is not the same as that of b 's.
- (b) Let the set $D = \{p \mid p \text{ is a polynomial over the single variable } x, \text{ and } p \text{ has a root which is an integer (positive or negative)}\}$.
- (i) Design a Turing machine (TM) to accept D .
- (ii) Can D be decided by a TM? Justify your answer.

- C25. (a) Give a context-free grammar G that generates $L = \{0^i 1^j 0^k \mid i + k = j\}$. Prove that $L = L(G)$.
- (b) Write a regular expression for all strings of 0's and 1's in which the total number of 0's to the right of each 1 is even. Justify your answer.

- C26. Let $S = \{x_1, x_2, \dots, x_n\}$ be a set of n integers. A pair (x_i, x_j) (where $i \neq j$) is said to be the closest pair if $|x_i - x_j| \leq |x_{i'} - x_{j'}|$, for all possible pairs $(x_{i'}, x_{j'})$, $i', j' = 1, 2, \dots, n, i' \neq j'$.
- (a) Describe a method for finding the closest pair among the set of integers in S using $O(n \log_2 n)$ comparisons.
- (b) Now suggest an appropriate data structure for storing the elements in S such that if a new element is inserted to the set S or an already existing element is deleted from the set S , the current closest pair can be reported in $O(\log_2 n)$ time.
- (c) Briefly explain the method of computing the current closest pair, and necessary modification of the data structure after each update. Justify the time complexity.

- C27. Let A be an $n \times n$ matrix such that for every 2×2 sub-matrix $\begin{pmatrix} a & b \\ c & d \end{pmatrix}$ of A , if $a < b$ then $c \leq d$. Moreover, for any pair of rows i and j , if a_{ik} and a_{jl} are the largest elements in i -th and j -th rows of A , respectively, then $k \leq l$ (as illustrated in the 5×5 matrix below).

$$\begin{bmatrix} 3 & 4 & 2 & 1 & 1 \\ 7 & 8 & 5 & 6 & 4 \\ 2 & 3 & 6 & 6 & 5 \\ 5 & 6 & 9 & 10 & 7 \\ 4 & 5 & 5 & 6 & 8 \end{bmatrix}$$

- (a) Write an algorithm for finding the maximum element in each row of the matrix with time complexity $O(n \log n)$.
- (b) Establish its correctness, and justify the time complexity of the proposed algorithm.
- C28. Let M be an $(n \times n)$ matrix where each element is a distinct positive integer. Construct another matrix M' by permuting the rows and/or

permuting the columns, such that the elements of one row appear in *increasing* order (while looking from left to right) and those of one column appear in *decreasing* order (while looking from top to bottom).

- Describe an $O(n^2)$ time algorithm for constructing M' . Justify your analysis.
- Propose a data structure that supports your algorithm. Clearly explain how much additional storage, other than the matrix itself, is required in your algorithm.

C29. A connected, simple, undirected planar graph $G(V, E)$ is given where V denotes the set of vertices and E denotes the set of edges. In V , there is a designated source vertex s and a designated destination vertex t . Let $P(v)$ denote the shortest path (may contain repetition of nodes/edges) from s to t that passes through v , and let $l(v)$ denote the path length (i.e., the number of edges) of $P(v)$.

- Describe an $O(|V|)$ time algorithm that determines the value of τ where $\tau = \max_{v \in V} l(v)$. Justify your analysis.
- Propose a data structure that supports your algorithm.

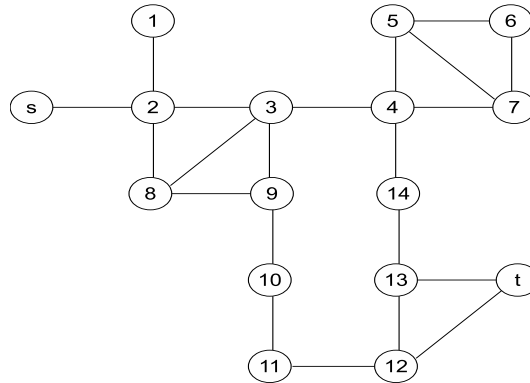

Figure 1: The example graph.

[For example, in the graph shown in Figure 1, $\tau = 10$, which corresponds to $P(6) : s \rightarrow 2 \rightarrow 3 \rightarrow 4 \rightarrow 7 \rightarrow 6 \rightarrow 7 \rightarrow 4 \rightarrow 14 \rightarrow 13 \rightarrow t$.]

- C30. The diameter of a tree $T = (V, E)$ is given by $\max_{u, v \in V} \{\delta(u, v)\}$, where $\delta(u, v)$ is the shortest path distance (i.e., the length of the shortest path) between vertices u and v . So, the diameter is the largest of all shortest path distances in the tree.
- Write pseudo-code for an efficient algorithm to compute the diameter of a given tree T .
 - Analyze the time complexity of your algorithm.
 - What is its space complexity?
 - Clearly mention the data structure(s) used by your algorithm.
 - A vertex c is called a center of a tree T if the distance from c to its most distant vertex is the minimum among all vertices in V . Write an algorithm to determine and report a center of the given tree T .

- C31. Consider three parallel lines L_1, L_2 and L_3 . On each line L_i , a set of n points $\{p_{i1}, p_{i2}, \dots, p_{in}\}$ is placed.

The objective is to identify a triplet of indices (k, ℓ, m) (if exists) such that a straight line can pass through $p_{1k}, p_{2\ell}$ and p_{3m} on L_1, L_2 and L_3 respectively. [See the following two figures for a demonstration.]

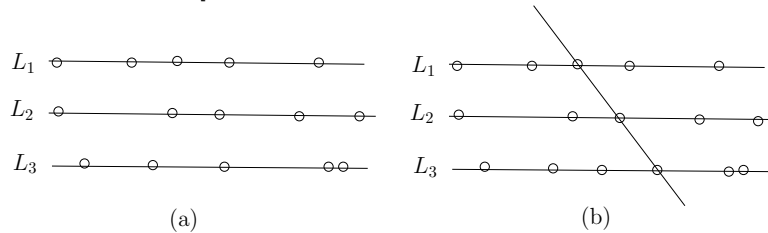

In Figure (a), there does not exist any triplet (k, ℓ, m) such that a straight line can pass through $p_{1k}, p_{2\ell}$ and p_{3m} . In Figure (b), the triplet $(3, 3, 4)$ is a solution since a straight line passes through p_{13}, p_{23} and p_{34} .

Present an efficient algorithm for solving this problem. Justify its correctness and worst case time complexity.

[Full credit will be given if your algorithm is correct, and of worst case time complexity $O(n^2)$.]

- C32. Let $a_1 = 1, a_2 = 2,$ and $a_n = a_{n-1} + a_{n-2} + 1$ for $n > 2$.

- Express 63 as a sum of distinct a_i 's.

- (b) Write an algorithm to express any positive integer k as a sum of at most $\lceil \log_2 k \rceil$ many distinct a_i 's.
- (c) Prove the correctness of your algorithm.

- C33. (a) How many distinct labeled spanning trees does a complete graph of n vertices have? Give a formal argument to establish your answer.
- (b) A least expensive connection route among n houses needs to be designed for a cable-TV network. Consider the following algorithm \mathcal{A} for finding a spanning tree.

Algorithm \mathcal{A}

Input: $G = (V, E)$

Output: Set of edges $M \subseteq E$

Sort E in decreasing order of cost of edges;

$i \leftarrow 0$;

while $i < |E|$ **do**

begin

 Let $temp = (u_1, u_2)$ be the i -th edge $E[i]$ in E ;

 Delete $E[i]$, i.e., replace $E[i]$ by ϕ ;

if u_1 is disconnected from u_2 **then**

 restore $temp$ in list E as $E[i]$;

$i \leftarrow i + 1$;

end

return the edges in E which are not ϕ ;

- (i) Prove that the algorithm \mathcal{A} can be used to correctly find a least cost connection route, given a set of n houses and information about the cost of connecting any pair of houses.
- (ii) What is the worst case time complexity of \mathcal{A} ?
- (iii) If all the edges have distinct cost, how many solutions can there be?

- C34. (a) Let $T = (V, E)$ be a tree, and let $v \in V$ be any vertex of T .
- The *eccentricity* of v is the maximum distance from v to any other vertex in T .
 - The *centre* C of T is the set of vertices which have the minimum eccentricity among all vertices in T .

- The *weight* of v is the number of vertices in the largest subtree of v .
- The *centroid* G of T is the set of vertices with the minimum weight among all vertices in T .

Construct a tree T that has disjoint centre and centroid, each having two vertices, i.e., $C \cap G = \emptyset$ and $|C| = |G| = 2$.

- (b) A vertex cover of a graph $G = (V, E)$ is a set of vertices $V' \subseteq V$ such that for any edge $(u, v) \in E$, either u or v (or both) is in V' . Write an efficient algorithm to find the minimum vertex cover of a given tree T . Establish its correctness. Analyse its time complexity.

C35. You are given k sorted lists, each containing m integers in ascending order. Assume that (i) the lists are stored as singly-linked lists with one integer in each node, and (ii) the head pointers of these lists are stored in an array.

- Write an efficient algorithm that merges these k sorted lists into a single sorted list using $\Theta(k)$ additional storage.
- Next, write an efficient algorithm that merges these k sorted lists into a single sorted list using $\Theta(1)$ additional storage.
- Analyse the time complexity of your algorithm for each of the above two cases.

C36. (a) Assume you have a chocolate bar containing a number of small identical squares arranged in a rectangular pattern. Our job is to split the bar into small squares by breaking along the lines between the squares. We obviously want to do it with the minimum number of breakings. How many breakings will it take?

- (b) Consider that the chocolate bar has n breaking lines along the length and m breaking lines along the breadth. Write a C function that will take n, m as inputs and print the line numbers along the length and the breadth according to your strategy of breaking the chocolate.

C37. (a) Let \mathcal{B} be a rooted binary tree of n nodes. Two nodes of \mathcal{B} are said to be a sibling pair if they are the children of the same parent. For example, given the binary tree in the figure below, the sibling

pairs are (2, 3) and (6, 7). Design an $O(n)$ time algorithm that prints all the sibling pairs of \mathcal{B} .

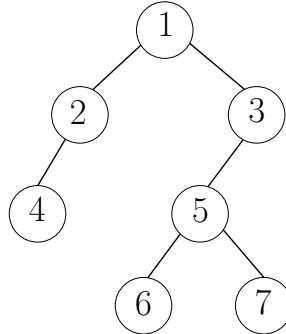

- (b) Let \mathcal{H}_1 and \mathcal{H}_2 be two complete binary trees that are heaps as well. Assume \mathcal{H}_1 and \mathcal{H}_2 are max-heaps, each of size n . Design and analyze an efficient algorithm to merge \mathcal{H}_1 and \mathcal{H}_2 to a new max-heap \mathcal{H} of size $2n$.
- C38. (a) Let A and B be two arrays, each containing n distinct integers. Each of them is sorted in increasing order. Let $C = A \cup B$. Design an algorithm for computing the median of C as efficiently as you can.
- (b) Let $G = (V, E)$ be an undirected weighted graph with all edge weights being positive. Design an efficient algorithm to find the *maximum* spanning tree of G .
- C39. (a) Construct a deterministic finite automaton accepting the following language:
 $\{w \in \{0, 1\}^* : w \text{ has an equal number of } 01\text{'s and } 10\text{'s}\}$.
 For example, 101 is in the language because it contains one instance of 10 and one instance of 01 as well.
- (b) Consider the following statement:
For all languages $L \subseteq \{0, 1\}^$, if L^* is regular then L is regular.*
 Is the above statement true? Justify your answer.

- C40. (a) The average memory access time for a microprocessor with first level cache is 3 clock cycles.
- If data is present in the cache, it is found in 1 clock cycle.
 - If data is not found in the cache, 100 clock cycles are needed to get it from off-chip memory.

It is desired to obtain a 50% improvement in average memory access time by adding a second level cache.

- This second level cache can be accessed in 6 clock cycles.
- The addition of this second level cache does not affect the first level cache.
- Off-chip memory accesses still require 100 clock cycles.

To obtain the desired speedup, how often must data be found in the second level cache?

- (b) Two modules M_1 and M_2 of an old machine are being replaced by their improved versions M_3 and M_4 , respectively in a new machine. With respect to the old machine, the speed-up of these modules (M_3 and M_4) are 30 and 20, respectively. Only one module is usable at any instant of time. A program P , when run on the old machine, uses M_1 and M_2 for 30% and 20% of the total execution time, respectively. Calculate the overall speed-up of P when it is executed on the new machine.

- C41. (a) Two queries equivalent to each other are specified for a relation $R(A, B, C, D, E, F)$. The queries are:

- $\pi_{A,B,C}(\sigma_{B>500}(R))$
- $\sigma_{B>500}(\pi_{A,B,C}(R))$

The system maintains a $B+$ tree index for (A, B, C) on R . However, the index is unclustered. The relation R occupies 100 pages and the index structure needs 5 pages only. Compute the number of disk accesses required for each of the queries and thereby decide which one of the two queries will be preferred by the query optimizer for minimum cost of execution. The cost of query execution is primarily dependent on the number of disk accesses.

- (b) In a LAN, n^2 routers are connected in an $n \times n$ mesh such that $R(i, j)$ represents a router in the i -th row and j -th column of the mesh.

- (i) Find how many distinct shortest paths exist between two routers $R(i_1, j_1)$ and $R(i_2, j_2)$ ($1 \leq i_1, j_1, i_2, j_2 \leq n$). Two paths are distinct if they differ in at least one link.
- (ii) At most how many of these distinct shortest paths will be node disjoint, i.e., with no common node except the source and the destination? Justify your answer.

C42. (a) Consider a uniprocessor system with four processes having the following arrival and burst times:

	Arrival Time	CPU Burst Time
P1	0	10
P2	1	3
P3	2.1	2
P4	3.1	1

- (i) Calculate the average waiting time and also the average turnaround time if shortest (remaining) job first (SJF) scheduling policy is used with pre-emption. Assume that the context switching time is zero. Note that in SJF, if at any point there is a tie, then the job that arrived earlier will get priority.
 - (ii) Now consider the continuous arrival of new jobs at times 4, 5, 6, 7, ...following $P4$, with CPU burst times of 2 units each. In this case, what will be the turnaround time of $P1$? Justify your answer.
- (b) A heavily loaded 1 km long, 10 Mbps token ring network has a propagation speed of 200 meter per micro-second. Fifty stations are uniformly spaced around the ring. Each data packet is 256 bits long, including 32 bits of header. The token is of 8 bits. What is the effective data rate of the network assuming the stations always have packets to transmit?

ELECTRICAL AND ELECTRONICS ENGINEERING

- E1. (a) Consider the multiplication of two 2-bit integers a_1a_0 and b_1b_0 to get a 4-bit output $c_3c_2c_1c_0$. Design a circuit for deriving the bit c_2 using only 2-input NAND gates.
- (b) Consider a bit sequence a_i , $i \geq 0$ which has the property $a_{i+4} = a_{i+1} \oplus a_i$.
- To generate this sequence, which bits of the sequence need to be initialized?
 - Design a logic circuit using flip-flops and NAND gates to generate the above bit sequence.
 - For any given value of i , identify the points in the circuit at which the values of $a_i, a_{i+1}, \dots, a_{i+4}$ may be obtained.
- E2. (a) Let us consider a house with two lights; one is at porch gate (porch light denoted by PL) and another is inside the room (room light denoted by RL). The lights are controlled by three switches A , B and C , out of which two are inside the house and one is outside the house. Both the lights are OFF when all the switches are OFF. Both the lights are ON when all the three switches are ON. If any two switches are ON then the porch light is ON. If only one of A , B and C is ON then the light inside the room is ON. Write boolean functions for PL and RL in terms of switch variables A , B and C .
- (b) Design a special purpose synchronous counter with not more than 3 flip-flops to provide the following output:

→ 000, 000, 010, 000, 100, 000, 110, 000

You may use additional combinational circuits as needed.

- E3. A resistor R is getting supply from n e.m.f. sources e_1, e_2, \dots, e_n where $e_1 < e_2 < \dots < e_n$, connected with corresponding resistors as shown in the figure below.

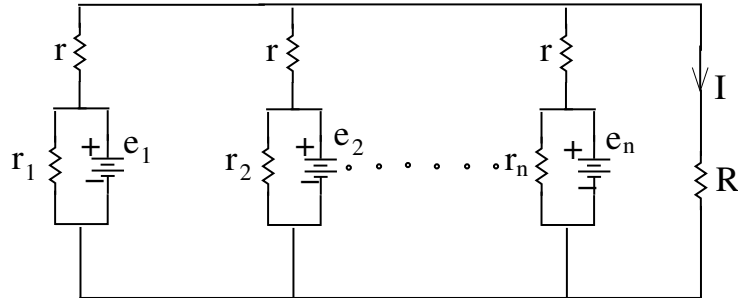

Calculate the current I flowing through the resistor R .

- E4. (a) A 44 KW, 220 V d.c. machine has 110Ω shunt resistance and 0.05Ω armature resistance. Calculate total armature power developed when the machine is working as (i) a generator and (ii) a motor.
- (b) Test data of a 200/400 V, 10 KVA, 50 Hz single phase transformer is as follows.
 Short circuit test on secondary side: 20 V, 10 A, 80 W
 Open circuit test on primary side: (i) 200 V, 50 Hz, 2500 W
 (ii) 100 V, 25 Hz, 1000 W
 At full-load and unity power factor, calculate:
 (i) copper loss,
 (ii) hysteresis loss, and
 (iii) eddy current loss.
- E5. (a) In the following circuit, the diodes D_1 and D_2 and the capacitors C_1 and C_2 are assumed to be ideal. At the input, a sinusoidal voltage $V_1 \sin(\omega t)$ is applied. Sketch the output waveform $V_o(t)$ as a function of time t .

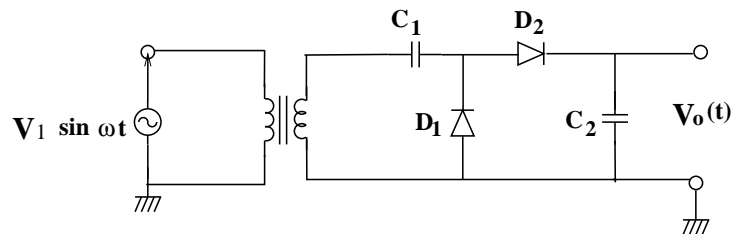

- (b) Consider the following circuit with two ideal OP-Amps. Calculate the output voltage, V_o .

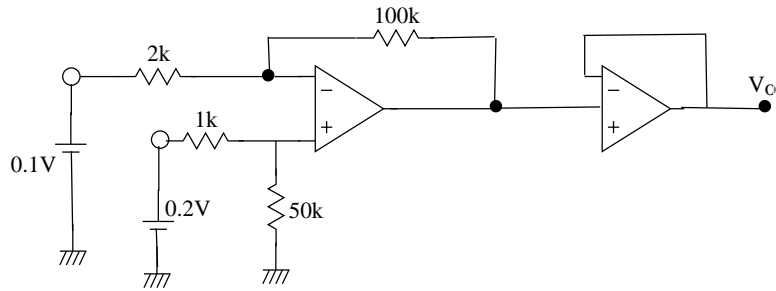

E6. Open-circuit and short-circuit tests are conducted on a 220/440 V, 4.4 KVA, single phase transformer. The following readings are obtained.

Open Circuit test with voltage applied on low-voltage side:

Voltage = 110 V,
 Current = 1.1A, and
 Power = 150 W.

Short Circuit test with voltage applied on high-voltage side:

Voltage = 24 V,
 Current = 8A, and
 Power = 64 W.

At 0.8 p.f. lagging, calculate

- (i) the efficiency of the transformer at full-load, and
- (ii) the output voltage at the secondary terminal when supplying full-load secondary current.

E7. Consider a voltage amplifier circuit shown in the figure below, where R_i and R_o represent the input and output impedances respectively, C_0 is the total parasitic capacitance across the output port, μ is the amplifier gain and the output is terminated by a load resistance R_L .

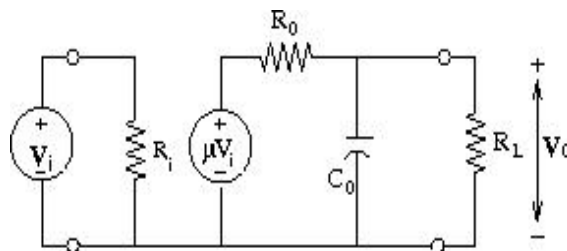

- (a) Calculate the current, voltage and power gain in decibels (dB) of the amplifier, when
 $R_i = 1M\Omega$, $R_L = 600\Omega$, $R_0 = 100M\Omega$, $C_0 = 10pf$, $\mu = 10$.
- (b) Calculate the 3-dB cutoff frequency of the amplifier when
 $R_i = 5K\Omega$, $R_L = 1K\Omega$, $R_0 = 100\Omega$, $C_0 = 10pf$, $\mu = 2$.

E8. Assume that an analog voice signal which occupies a band from 300 Hz to 3400 Hz, is to be transmitted over a Pulse Code Modulation (PCM) system. The signal is sampled at a rate of 8000 samples/sec. Each sample value is represented by 7 information bits plus 1 parity bit. Finally, the digital signal is passed through a raised cosine roll-off filter with the roll-off factor of 0.25. Determine

- (a) whether the analog signal can be exactly recovered from the digital signal;
- (b) the bit duration and the bit rate of the PCM signal before filtering;
- (c) the bandwidth of the digital signal before and after filtering;
- (d) the signal to noise ratio at the receiver end (assume that the probability of bit error in the recovered PCM signal is zero).

E9. (a) Given a library of 2-input AND, NOT and 2-input XOR gates, synthesize the function $f(A, B, C, D)$ as shown in the Karnaugh map below, using minimum number of gates of the library.

		CD			
	AB	00	01	11	10
00		1		1	
01			1	1	
11			1		1
10			1	1	

- (b) A sequential lock circuit has two push-buttons **A** and **B** which cannot be pressed simultaneously. It has one output **z** which becomes 1 and opens the lock, only when the buttons are pressed in the sequence **ABBA**. Find a reduced state table for the lock circuit.

- E10. Consider the following waveform of a signal $f(t) = 3 \cos 500t + 4 \cos 1500t$ volts, which is coded using Delta Modulation (DM).
- Compute the minimum integer sampling rate with justification for exact reconstruction of the signal from the sampled data.
 - Assuming a quantizer step size of $\frac{1}{2}$ volt, determine the mean-square quantization noise power.
 - Determine the cut-off frequency of the low-pass filter in the DM receiver and calculate the corresponding signal-to-noise ratio.
- E11. (a) Consider the discrete-time sequence

$$x[n] = \begin{cases} (-0.5)^n & n \geq 0 \\ 0 & \text{otherwise.} \end{cases}$$

- Determine the inverse Z-transform of $X(z^3)$ without computing $X(z)$.
 - Let $y[n] = e^{j(\pi/3)n}x[n]$. Sketch the pole-zero plot and indicate the Region of Convergence (ROC) of $Y(z)$.
- (b) Consider the complex sequence $v[n] = \text{Re}\{v[n]\} + j\text{Im}\{v[n]\}$. Compute the Z-transform of $\text{Im}\{v[n]\}$ in terms of $V(z)$ and indicate the ROC of $\text{Im}\{v[n]\}$ in terms of the ROC of $V(z)$.
- E12. A prism is made of wire mesh with each side having equal resistance R (see the figure given below). A battery of 6 V and zero internal resistance is connected across E and F. If R is 0.5Ω , find the current in the branch AD.

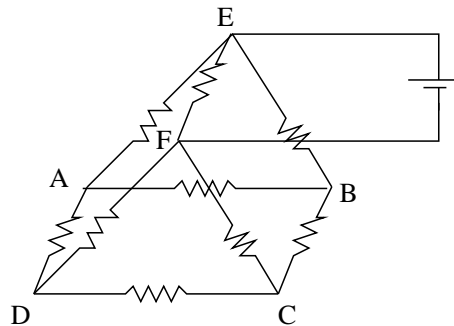

- E13. (a) Consider a discrete memoryless source with source alphabet $S = \{s_0, s_1, s_2, s_3\}$ with respective probabilities

$$p_0 = \frac{1}{8}; \quad p_1 = \frac{1}{8}; \quad p_2 = \frac{1}{2}; \quad p_3 = \frac{1}{4}.$$

Calculate the probabilities and entropy of the second-order extension of the source.

- (b) Suppose a long sequence of information is composed of five possible symbols with probabilities given in the table below:

Symbol	s_0	s_1	s_2	s_3	s_4
Probability	0.4	0.2	0.1	0.1	0.2

Encode the above set of symbols with strings of 0's and 1's based on Huffman coding. Calculate the average code-word length.

- E14. (a) A sequence $x[n]$ of length 8 has a Discrete Fourier Transform (DFT) $X[k]$ as follows:

$$X[k] = \begin{cases} 1; & k = 0, 1, 2, 3 \\ k - 2; & k = 4, 5, 6, 7 \\ 0; & \text{otherwise.} \end{cases}$$

$x[n]$ is now up-sampled by a factor of 2 by inserting a zero between every pair of samples of $x[n]$, and appending a zero at the end to produce a sequence $y[n]$ of length 16. Sketch $Y[k]$, the 16-point DFT of $y[n]$.

- (b) A zero-mean, wide-sense stationary sequence with variance σ_x^2 passes through a stable and causal all-pass filter with z-transform

$$H(z) = \frac{\alpha - z^{-1}}{1 - \alpha z^{-1}}.$$

Determine the range of values that α can take. Also calculate the power spectrum of the output, i.e., the Discrete Time Fourier Transform (DTFT) of the auto-correlation sequence of the output.

- E15. (a) Design a digital circuit to compare two three bit numbers $A = a_2a_1a_0$ and $B = b_2b_1b_0$; the circuit should have three outputs indicating $A = B$, $A < B$ and $A > B$. Give a gate-level diagram of this comparator circuit.
- (b) Using two such comparator circuits and as few basic gates as possible, design a digital circuit to compare two six bit numbers $A = a_5a_4a_3a_2a_1a_0$ and $B = b_5b_4b_3b_2b_1b_0$. This circuit should also have only three outputs indicating $A = B$, $A < B$ and $A > B$.

- E16. (a) Consider an OP-AMP circuit with a diode D , resistance R and a d.c. source voltage V_1 as shown below. At the input, a voltage signal $V_2 \sin \omega t$ is applied, where $V_2 > V_1$. Trace the plot of output voltage V_0 against time. Assume that both the OP-AMP and the diode are ideal.

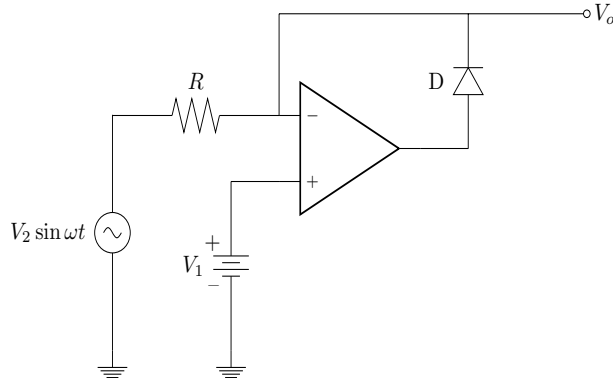

- (b) Consider the following circuit with two ideal OP-AMPs. The values of the resistances and input sources are shown in the figure. Calculate the output voltage V_0 . Show your analysis and justify your argument.

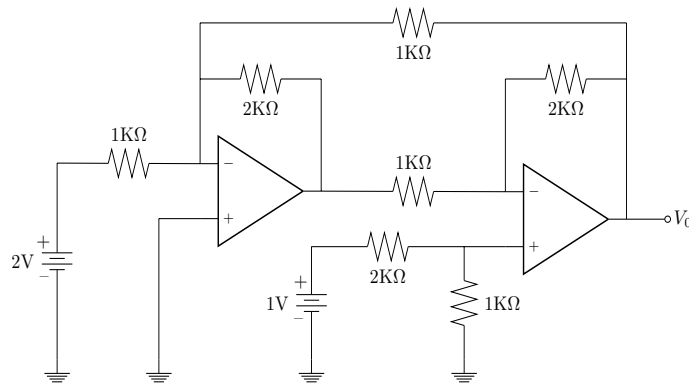

- E17. A 22 KVA, 2200/220V two-winding transformer is converted to an auto-transformer with additive polarity.

- (a) Calculate the percent increase in KVA of the auto-transformer with respect to the original two-winding transformer.
- (b) The auto-transformer has a full-load efficiency of 90% at unity power factor. Calculate the efficiency of the auto-transformer

when the load is reduced to half at the same power factor. Assume that iron loss is 100 W.

- E18. Consider the following circuit, where a sinusoidal source $V_1 \sin \omega t$ and a DC source V_2 are connected as shown. Assume $V_1 > V_2$. Let V_{AB} be the voltage between A and B . The value of each resistance is R .

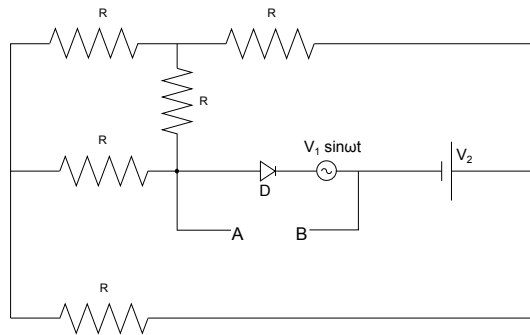

The voltage sources and the diode D are assumed as ideal. Draw the waveform of V_{AB} and justify your answer.

- E19. Consider the following circuit. An a.c. source $V_1 \sin \omega t$ is connected to the non-inverting input of the OP-AMP. Draw the voltage waveform V_{AB} and justify your answer.

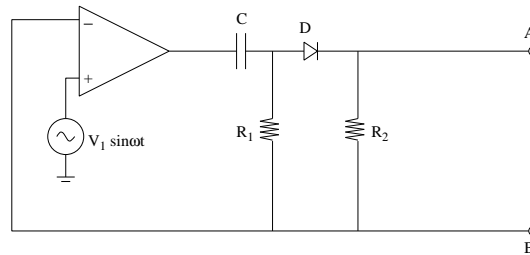

- E20. Two d.c. generators A and B are connected to a common load. A has constant *e.m.f.* of $400V$ and internal resistance 0.25Ω , while B has constant *e.m.f.* of $410V$ and internal resistance 0.40Ω .

- Calculate the current and power output from each generator to the common load having terminal voltage of $390V$.
- What change in operation will happen when the common load is open circuited?

- (c) Under the open circuit condition, calculate the current, terminal voltage and energy output from each generator.

- E21. (a) Use Norton's theorem in the circuit given below to find the voltage between the points A and B.

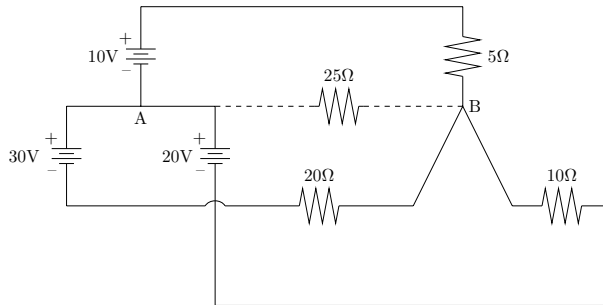

- (b) If a 25Ω resistance is connected between A and B, what will be the current through the resistor?
 (c) Using the Norton's theorem, find the voltage V_0 in the following figure.

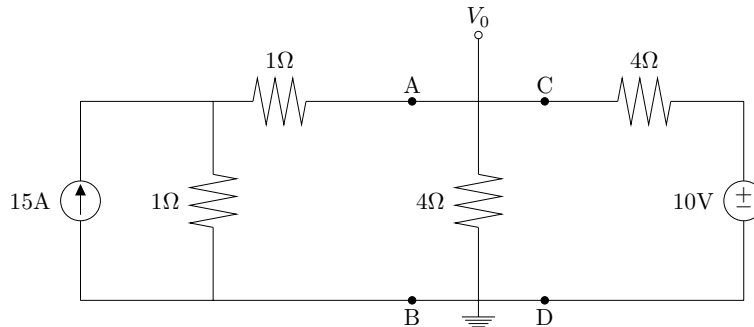

- E22. Consider the following circuit. The emf $E = 15V$, $R_1 = 1.5K\Omega$, and $R_2 = 3.0K\Omega$. The switch is closed for $t < 0$, and steady-state conditions are established. The switch is now thrown open at $t = 0$.

- (a) Find the initial voltage emf_0 across L just after $t = 0$. Which end of the coil is at higher potential: A or B?
 (b) Draw freehand graphs of the currents in R_1 and R_2 as a function of time, indicating the values before and after $t = 0$.

- E23. For the circuit shown below, assume $\beta = h_{FE} = 100$,

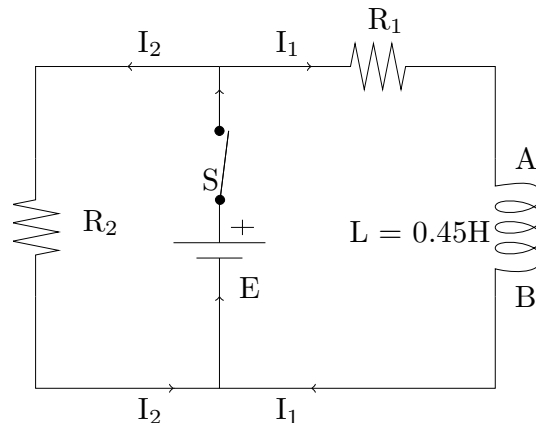

$V_{CE, \text{sat}} = 0.2\text{V}$, $V_{BE, \text{sat}} = 0.8\text{V}$, $V_{BE, \text{active}} = 0.7\text{V}$, and $V_{BE, \text{cutoff}} = 0.0$. [All symbols follow the standard notations.]

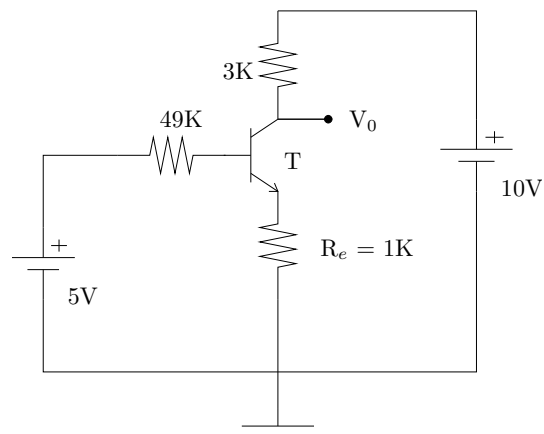

- Determine whether the transistor T is in the *cutoff*, *saturation* or *active* region.
- Find the minimum value of R_e for which the transistor is in the active region. [Assume $I_{CO} \ll I_B$]

- E24. (a) Given the circuit shown below, find the condition under which the current through R will be zero.

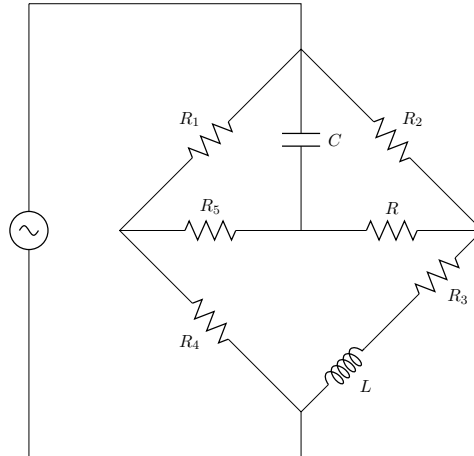

- (b) Find the current in 8Ω load across AB of the following circuit.

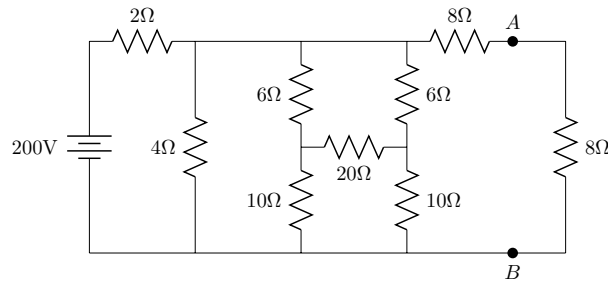

- E25. (a) Consider two 2-bit unsigned integers $A = a_1a_0$ and $B = b_1b_0$. We like to compute $(A \cdot B) \bmod 3$.
- How many bits are required to represent the result?
 - Design a Boolean circuit using only two-input NAND gates that accepts a_0 , a_1 , b_0 and b_1 as inputs and computes the result.
- (b) Consider the synchronous circuit consisting of four D flip-flops as shown in the figure below. All the flip-flops are driven by the same clock signal (not explicitly shown in the figure). This circuit generates a periodic binary output sequence '1100101000' repeatedly with the leftmost bit appearing first at the output. Initially, $x_1 = 1$, $x_2 = 1$, $x_3 = 0$ and $x_4 = 0$. Find a minimal expression for the combinational circuit $f(x_1, x_2, x_3, x_4)$.

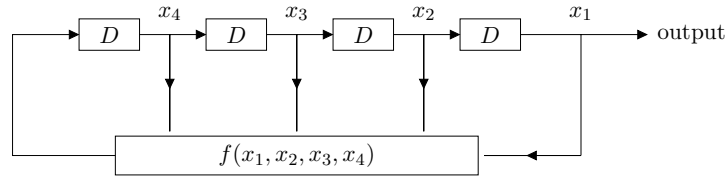

- E26. (a) The equivalent noise resistance for a multi-stage amplifier is the input resistance that will produce the same random noise at the output of the amplifier as the actual amplifier does.

The first stage of a two-stage amplifier has a voltage gain of 10, a 600Ω input resistance, a 1600Ω equivalent noise resistance and a $30\text{ k}\Omega$ output resistance. For the second stage, these values are 25, $80\text{ k}\Omega$, $10\text{ k}\Omega$ and $1\text{ M}\Omega$, respectively. Calculate the equivalent input noise resistance of this two-stage amplifier.

For an input noise resistance R , the noise voltage E_n generated at the input of a circuit is $E_n = \sqrt{4kT\Delta fR}$, where k is the Boltzmann constant, T is the temperature and Δf is the bandwidth.

- (b) Consider the circuit shown below.

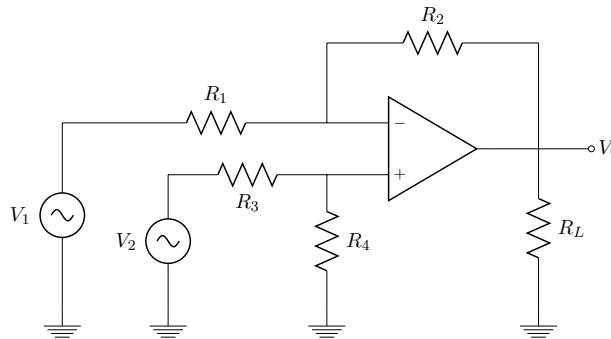

- (i) What would be the value of V_0 for an ideal OP-AMP if $R_1 = R_2 = R_3 = R_4$?
- (ii) What type of amplifier is represented by the above circuit?
- E27. (a) Consider that only the four alphabets a, b, c, d are used in a communication between two parties. Studying a good amount of data, it has been noted that the expected probabilities of occurrences of these four alphabets are 0.41, 0.31, 0.21 and 0.07, respectively. You are required to encode these alphabets as binary strings so that the average length of the encoded bitstream is minimum. The lengths of the codewords may be different.

The encoded binary string will not have any separating character between any two codewords and the recipient should be able to decode the binary string to revert back to the alphabets sent.

- (i) Write down the four binary codewords corresponding to a , b , c and d .
 - (ii) Explain how you arrive at them.
 - (iii) What is the average bit-length per alphabet for your coding scheme?
- (b) A frequency modulated (FM) signal is represented as

$$e = 12 \sin(1.8\pi \times 10^8 t + 5 \sin 400\pi t).$$

Find the carrier and modulating frequencies, and the maximum deviation of the FM wave. What power will this FM wave dissipate in a 10Ω resistor?

- E28. (a) Consider the following circuit where the capacitors and the inductor are ideal. At time $t = 0$, the switch S is open and at time $t = 1$, S is connected to node A . At time $t = 2$, S is disconnected from node A and connected to node B .
- (i) Write an expression of the current $i_1(t)$.
 - (ii) Plot the waveform of $i_2(t)$ against time t .

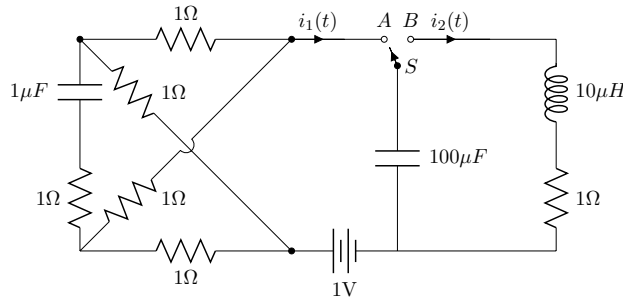

- (b) Consider the following circuit with three resistors, three diodes D_1 , D_2 , D_3 and one AC source $V \sin wt$. Assume that the OP-AMP and the diodes are ideal.
- (i) Show the voltage waveforms at v_1 and v_2 with respect to time t .
 - (ii) What is the maximum value of v_1 and v_2 ?

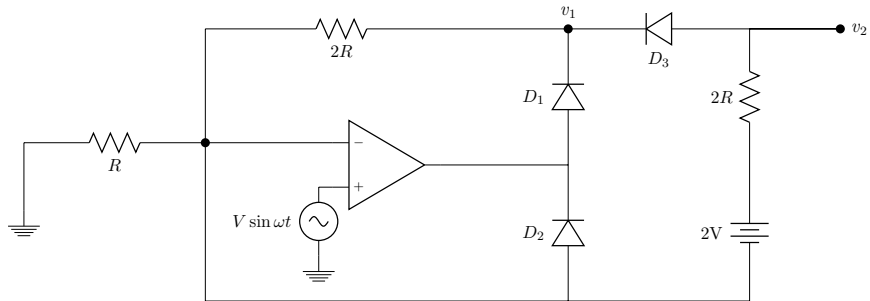

- E29. (a) A 50 Hz, 4-pole, 3-phase induction motor is running at 1200 rpm. It is connected to a 440V power line. It requires power input of 33 kW at 0.8 power factor lag. The motor has stator loss 1 kW and windage and friction loss 1.6 kW.
- Find the rotor copper loss.
 - Find the efficiency of the induction motor.
- (b) A shunt generator delivers 100 kW at 250V and 400 rpm. The armature resistance is 0.02Ω and field resistance is 50Ω . The total contact drop for the brush is 2V. Calculate the speed of the machine running as a shunt motor and taking 50 kW input at 250V.
- E30. (a) A single phase 440/220V transformer has an effective primary resistance of 1Ω and secondary resistance of 0.11Ω . Its iron loss on normal input potential is 64W. Calculate maximum efficiency of the transformer at unity power factor.
- (b) Let $f(x)$, $x = 0, 1, 2, \dots, N-1$, be real periodic input data with periodicity N . Let $F(u)$, $u = 0, 1, 2, \dots, N-1$, be the discrete Fourier transform of $f(x)$. Compute the Fourier coefficients and phase angles for $f(x) = [10, 5, 7, 11, 17, 11, 7, 5]$ and $N = 8$, and indicate if these coefficients reflect any special property.

MATHEMATICS

Unless otherwise specified,
 \mathbb{N} denotes the set of positive integers.
 \mathbb{Z} denotes the set of integers;
 \mathbb{Q} denotes the set of rational numbers;
 \mathbb{R} denotes the set of real numbers;
 \mathbb{C} denotes the set of complex numbers;

Algebra

- M1. Find all ring automorphisms of $\mathbb{Q}[X]$ where \mathbb{Q} denotes the field of rational numbers.
- M2. In the additive group of rational numbers, show that the group generated by any two elements is cyclic.
- M3. Give two non-isomorphic field extensions of degree 2 of the field \mathbb{Q} of rational numbers. Justify your answer.
- M4. Let $\mathbb{Z}[X]$ denote the ring of polynomials in X with integer coefficients. Find an ideal I in $\mathbb{Z}[X]$ such that $\mathbb{Z}[X]/I$ is a field of order 4.
- M5. Let F be a field whose multiplicative group is cyclic. Show that there exists a prime number p such that $px = 0$ for each x in F .
- M6. Let G be a finite group admitting no nontrivial automorphisms. Show that G has at most two elements.
- M7. If m and n are distinct natural numbers, then show that the abelian groups \mathbb{Z}^m and \mathbb{Z}^n are not isomorphic.
- M8. Let I be the ideal of the polynomial ring $\mathbb{Z}[X]$ generated by $X^2 + X + 1$ and 5. Is the quotient ring $\mathbb{Z}[X]/I$ a field? Justify your answer.

- M9. Let I be the ideal generated by $X - 3$ and 7 in the polynomial ring $\mathbb{Z}[X]$. Show that, for each $f(X) \in \mathbb{Z}[X]$, there exists a unique integer $a, 0 \leq a \leq 6$, such that $f(X) - a \in I$.
- M10. If G is a group of order 111 with exactly two elements of order 3 then show that G is cyclic.
- M11. A ring R is said to be of characteristic m (m a positive integer) if $x + \cdots + x$ (m times) $= 0$ for all $x \in R$. Show that any ring of characteristic pq (p, q prime) is the direct sum of a ring of characteristic p and one of characteristic q .
- M12. Let F be an algebraically closed field of finite characteristic p . Let $q = p^e, e \geq 1$. Show that $x \rightarrow x^q$ is an automorphism of F into itself. Conclude that there is a unique subfield F_q of F having q elements and that F_q consists of the zeroes of the polynomial $X^q - X$.
- M13. Show that the additive group of complex numbers is isomorphic to the additive group of real numbers.
(Hint : Consider these as vector spaces over an appropriate field.)
- M14. Let S_n denote the group of permutations of $\{1, 2, 3, \dots, n\}$ and let k be an integer between 1 and n . Find the number of elements x in S_n such that the cycle containing 1 in the cycle decomposition of x has length k .
- M15. Let σ be a permutation of $\{1, 2, 3, \dots, n\}, n$ odd. Show that

$$(\sigma(1) - 1)(\sigma(2) - 2) \dots (\sigma(n) - n)$$

is even.

- M16. Let $\phi : G \rightarrow \mathbb{C}^*$ be a non-constant group homomorphism from a finite group G to the multiplicative group of non-zero complex numbers. Show that

$$\sum_{g \in G} \phi(g) = 0.$$

- M17. Let ψ be an automorphism of the additive group $\mathbb{Z}/77\mathbb{Z}$ of the integers mod 77. Show that ψ^{60} is the identity automorphism (here ψ^{60} means the 60-fold composition of ψ with itself).
- M18. Let a, b be two elements of a field F with $a \neq 0$. Prove that a polynomial $f(x) \in F[x]$ is irreducible if and only if the polynomial $f(ax + b)$ is irreducible.
- M19. Let f, g be two polynomials in $\mathbb{Z}[x]$. Prove that the ideal generated by them in $\mathbb{Z}[x]$ contains a non-zero integer if and only if they are relatively prime in $\mathbb{Q}[x]$.
- M20. Show that the polynomial $x^3 - 2x + 3$ can not be split as a product of two non-constant polynomials in $\mathbb{Q}[x]$.
- M21. Let f be an irreducible cubic polynomial with rational coefficients and let K be an extension of \mathbb{Q} of degree ten. Prove or disprove: f remains irreducible in $K[x]$.
- M22. Determine the group of automorphisms of the permutation group S_3 on 3 elements.
- M23. Find the number of elements of order 6 in the permutation group S_6 on six symbols.
- M24. Show that the ideal generated by 2 and x in the ring $\mathbb{Z}[x]$ of polynomials over the ring of integers cannot be generated by one element.
- M25. Prove that the rings (without identity) $2\mathbb{Z}$ and $3\mathbb{Z}$ are not isomorphic (as rings).
- M26. Can the ideal $I = \{f : [0, 1] \rightarrow \mathbb{R}, f(\frac{1}{2}) = 0\}$ in the ring R of all functions from $[0, 1]$ to \mathbb{R} be generated by one element?
- M27. Let K be a subfield of \mathbb{C} that is not contained in \mathbb{R} . Show that K is dense in \mathbb{C} .

- M28. Let g be an element of order 143 in a group G . Show that there are unique elements g_1, g_2 in G satisfying:
- I. $g = g_1 g_2 = g_2 g_1$,
 - II. Order of $g_1 = 11$, Order of $g_2 = 13$.

- M29. Let A be any ring without zero divisors; that is, $xy = 0$ implies either $x = 0$ or $y = 0$. If $a, b \in A$ satisfy $a^m = b^m, a^n = b^n$ for two fixed relatively prime natural numbers m, n prove that $a = b$.

- M30. If F is a finite extension field of a field E and if $E \subseteq R \subseteq F$ for some subring R , then prove that R is also a field.

- M31. Determine the additive group of the field of 4 elements.

- M32. Let \mathbb{C}^* denote the group of non-zero complex numbers under multiplication. Show that \mathbb{C}^* can be expressed as a direct product of two proper subgroups.

- M33. Let \mathbb{Q} denote the field of rational numbers. Let I be the principal ideal in the polynomial ring $\mathbb{Q}[x]$ generated by the polynomial $f(x) = x^4 - 1$, i.e.,

$$I = \{g(x)f(x) \mid g(x) \in \mathbb{Q}[x]\}.$$

Show that I is contained in exactly three prime ideals of $\mathbb{Q}[x]$.

- M34. Consider the following subgroup of S_4 .

$$B = \{Id, (1, 2)(3, 4), (1, 3)(2, 4), (1, 4)(2, 3)\}.$$

Show that B is a normal subgroup and S_4/B is isomorphic to S_3 .

- M35. Let R be a Ring with identity. Let I and J be two ideal in R . Suppose $\Phi : R \rightarrow R/I \times R/J$ defined by $\Phi(a) = (a + I, a + J)$ for $a \in R$, is a ring isomorphism. Show that $I \cap J = \{0\}$ and $I + J = R$.

- M36. Show that if the multiplicative group of a field is cyclic, then the field is finite.

- M37. Show that every finitely generated subgroup of the additive group of rational numbers is cyclic.
- M38. If I is a maximal ideal of the polynomial ring $\mathbb{Z}[X]$, show that $\mathbb{Z}[X]/I$ is a finite field.
- M39. Let S_n be the group of all permutations of the set $\{1, 2, \dots, n\}$. Find the number of conjugates of the n -cycle taking i to $i + 1$ for $1 \leq i \leq (n - 1)$ and n to 1.
- M40. Let \mathbb{C} be the field of complex numbers and $\varphi : \mathbb{C}[X, Y, Z] \rightarrow \mathbb{C}[t]$ be the ring homomorphism such that

$$\begin{aligned}\varphi(a) &= a \text{ for all } a \text{ in } \mathbb{C}, \\ \varphi(X) &= t, \\ \varphi(Y) &= t^2, \text{ and} \\ \varphi(Z) &= t^3.\end{aligned}$$

Determine the kernel of φ .

- M41. Show that there is no field isomorphism between $\mathbb{Q}(\sqrt{2})$ and $\mathbb{Q}(\sqrt{3})$. Are they isomorphic as vector spaces over \mathbb{Q} ?
- M42. Let \mathbb{Q}, \mathbb{R} denote the fields of rational numbers and real numbers respectively. Which of the following rings are *not* isomorphic.
- $\mathbb{Q}[x]/\langle x^2 + 1 \rangle$ and $\mathbb{Q}[x]/\langle x^2 + x + 1 \rangle$.
 - $\mathbb{R}[x]/\langle x^2 + 1 \rangle$ and $\mathbb{R}[x]/\langle x^2 + x + 1 \rangle$.
- Justify your answer.
- M43. Let S_4 denote the group of permutations of $\{1, 2, 3, 4\}$ and let H be a subgroup of S_4 of order 6. Show that there exists an element $i \in \{1, 2, 3, 4\}$ which is fixed by each element of H .
- M44. Let R be a commutative integral domain and K be a subring of R . If K is a field and the dimension of R as a vector space over K is finite, then show that R is a field.

- M45. Let a_1, a_2, \dots, a_n be real numbers satisfying $\sum_{k=1}^n \frac{a_k}{k} = 0$. Show that the polynomial $a_1 + a_2x + \dots + a_nx^{n-1}$ has a root in the interval $(0, 1)$.

Linear Algebra

- M46. Let $u = (u_1, u_2, \dots, u_n)$ be a fixed non-zero vector in \mathbb{R}^n such that $u_1 + u_2 + \dots + u_n = 0$, and let A be the $n! \times n$ matrix whose rows are the $n!$ permutations of u . Show that $\text{rank}(A) = n - 1$.
- M47. Let $u = (u_1, u_2, \dots, u_n)^T$ be a non-zero column vector in \mathbb{C}^n , and u^* be the row vector $(\bar{u}_1, \bar{u}_2, \dots, \bar{u}_n)$. Let $A = uu^*$. Find all the eigenvalues of A and identify the corresponding eigen subspaces.
- M48. Let $A = ((a_{ij}))$ be an $n \times n$ complex matrix. For $1 \leq k \leq n$, let $D_k \subseteq \mathbb{C}$ be the closed disc with center a_{kk} and radius $\sum_{\substack{j=1 \\ j \neq k}}^n |a_{jk}|$. If λ is any eigenvalue of A , then show that $\lambda \in D_k$ for at least one k .
(HINT: If \underline{x} is an eigenvector corresponding to the eigenvalue λ , look at the coordinate position k for which $|x_k|$ is largest.)
- M49. Let \mathbb{R}^n denote the n dimensional real vector space. Let A, B be two linear transformations on \mathbb{R}^n such that $A \circ A = A$ and $B \circ B = B$, where \circ stands for composition of linear transformations. Show that the ranges of $A - A \circ B$ and $B - A \circ B$ have only the zero vector in common.
- M50. Let V be the real vector space consisting of continuous real valued functions on \mathbb{R} . Show that the subset $\{\sin x, \cos x, e^x\}$ of V is linearly independent.
- M51. Let L and T be two linear transformations from a real vector space V to \mathbb{R} such that $L(v) = 0$ implies $T(v) = 0$. Show that $T = cL$ for some real number c .

M52. Let x_1, x_2, x_3, x_4 be vectors in \mathbb{R}^n such that the inner products $\langle x_i, x_j \rangle$, $i \neq j$, are strictly negative. Show that any three of the vectors x_1, x_2, x_3, x_4 are linearly independent.

M53. Let A be an $n \times n$ square matrix such that A^2 is the identity. Show that any $n \times 1$ vector can be expressed as a sum of at most two eigenvectors of A .

M54. Let A be an $m \times n$ matrix of rank 1 and G be an $n \times m$ matrix such that $AGA = A$. Show that the trace of AG is 1.

M55. Let

$$B = \begin{bmatrix} 0 & 1 & 0 & 0 \\ 0 & 0 & 1 & 0 \\ 0 & 0 & 0 & 1 \\ 0 & 0 & 0 & 0 \end{bmatrix}.$$

Show that, for each nonzero scalar λ , $(\lambda I - B)^{-1} = P_\lambda(B)$ for some polynomial $P_\lambda(X)$ of degree 3.

M56. Let C be an invertible, real matrix of order n . If each row sum of C is 1, then show that each row sum of C^{-1} also is 1.

M57. Let x and y be non-zero vectors in an inner product space over the field of real numbers. Then $\|x + y\| = \|x\| + \|y\|$ if and only if $x = \alpha y$ for some positive real number α .

M58. Suppose that A is a 2×2 matrix over reals such that $A^n = I$ for some integer n . Show that trace of A is at most 2.

M59. Find an $n \times n$ matrix over real numbers whose minimal polynomial is x^{n-1} .

M60. If A is a matrix with real entries such that $A^2 = A$ show that A is diagonalisable over \mathbb{R} .

M61. If A is an $n \times n$ upper triangular matrix with all diagonal entries 1, find the inverse of A as a polynomial in A .

M62. Let V_1, V_2, V_3 be three-dimensional subspaces of \mathbf{R}^4 . Show that $V_1 \cap V_2 \cap V_3$ contains a non-zero vector.

M63. Let $A = (a_{ij})_{1 \leq i, j \leq n}$ be a $n \times n$ matrix with

$$a_{ij} = \begin{cases} 1 & \text{if } i = 1, j = 2, \\ 1 & \text{if } i = j, \\ 0 & \text{otherwise.} \end{cases}$$

Prove that A is not a diagonalizable matrix over \mathbf{C} .

M64. Let M_2 be the space of all 2×2 complex matrices. Take

$$P = \begin{bmatrix} 1 & 0 \\ 0 & 0 \end{bmatrix} \text{ and } \mathcal{N} = \{X \in M_2 : PX = XP\}.$$

Show that if A, B are in \mathcal{N} then $AB = BA$.

M65. Let D be a $n \times n$ real, diagonal matrix. Show that there exists a $x \in \mathbb{R}^n$ such that

$$\text{span} \{D^k x : 0 \leq k \leq n - 1\} = \mathbb{R}^n$$

if and only if the eigen-values of D are distinct.

M66. Let A and B be $n \times n$, Hermitian matrices such that $AB = BA$. Suppose one of them has distinct eigenvalues. Show that A and B have a common eigenvector.

M67. Let A be an $m \times n$ real matrix with rank r and nullity k . Let V, W be the vector spaces of all real $n \times p, m \times p$ matrices, respectively. Define $L_A : V \rightarrow W$ by $L_A(X) = AX$ (left multiplication by A). Compute the rank and nullity of L_A .

M68. Let B, C be two invertible $n \times n$ complex matrices such that $BC = qCB$ for some complex number q . Show that $q^m = 1$ for some $m \geq 1$. (Hint: Consider the eigenvalues of BC and CB .)

M69. Let A be an $n \times n$ complex matrix such that $AX = XA$ for every invertible complex matrix X . Show that $A = \lambda I$ for some complex number λ .

M70. Let A_0, A_1 be $n \times n$ complex matrices which may not commute. Let $m \geq 2$ and $\omega = e^{\frac{2\pi i}{m}}$. Show that

$$m(A_0^m + A_1^m) = (A_0 + A_1)^m + (A_0 + \omega A_1)^m + (A_0 + \omega^2 A_1)^m + \dots + (A_0 + \omega^{m-1} A_1)^m.$$

M71. Let A and B be $n \times n$ matrices with real entries. Show that the matrix $\begin{pmatrix} A & I \\ I & B \end{pmatrix}$ has rank n if and only if A is nonsingular and $B = A^{-1}$.

M72. Let n be a positive odd integer and let A be a symmetric $n \times n$ matrix of integer entries such that $a_{ii} = 0$, $i = 1, 2, \dots, n$. Show that the determinant of A is even.

M73. Let A be a $n \times n$ real matrix with $A^2 = A^t$. Show that every real eigen-value of A is either 0 or 1.

M74. Suppose A, B, C are three $n \times n$ matrices such that A has n distinct eigenvalues. If $AB = BA$ and $AC = CA$, prove that $BC = CB$.

M75. Find a maximal linearly independent set in the following subset C of \mathbb{R}^{k+1} :

$$C = \left\{ (1, t, t^2, \dots, t^k) \in \mathbb{R}^{k+1} \mid t \in \mathbb{R} \right\}.$$

M76. Let A be a square matrix such that $A^k = 0$ for some $k > 0$. Prove that there exists an invertible matrix B such that BAB^{-1} is upper triangular with diagonal entries zero.

M77. Let S_n denote the group of all permutations of $\{1, 2, \dots, n\}$. For any $\sigma \in S_n$, denote by P_σ the linear transformation on \mathbb{R}^n given by

$$P_\sigma \begin{bmatrix} x_1 \\ x_2 \\ \vdots \\ x_n \end{bmatrix} = \begin{bmatrix} x_{\sigma^{-1}(1)} \\ x_{\sigma^{-1}(2)} \\ \vdots \\ x_{\sigma^{-1}(n)} \end{bmatrix}$$

where σ^{-1} denotes the inverse of σ . Show that the correspondence $\sigma \rightarrow P_\sigma$ is a homomorphism from the group S_n into the group of all

$n \times n$ orthogonal matrices. If $\epsilon(\sigma)$ denotes the signature (sign) of σ , show that $\sum_{\sigma \in S_n} \epsilon(\sigma) P_\sigma = 0$ for $n \geq 3$.

Number Theory and Combinatorics

M78. Find the number of squares in $[0, 8] \times [0, 8] \subseteq \mathbb{R}^2$ whose vertices have integer coefficients and the sides are parallel to the coordinate axes.

M79. For $n \geq 1$, let $f_n = 2^{2^n} + 1$. Show that if m and n are relatively prime then f_m and f_n are relatively prime. Hence show that there are infinitely many primes.

M80. Show that for $n \geq 2$, $1 + 1/2 + \dots + 1/2n$ is not an integer. You may use the fact that there is a prime p between n and $2n$ for $n \geq 2$.

(HINT: Show that such a prime divides the denominator of $1 + 1/2 + \dots + 1/2n$.)

M81. Let A_1, A_2, \dots, A_n be distinct subsets of a set X . Show that there exists a subset B of X having at most n elements such that $B \cap A_1, B \cap A_2, \dots, B \cap A_n$ are all distinct.

(HINT: Use induction on n .)

M82. (a) Show that $\binom{n}{k} = \sum_{m=k}^n \binom{m-1}{k-1}$.

(b) Prove that

$$\binom{n}{1} - \frac{1}{2} \binom{n}{2} + \frac{1}{3} \binom{n}{3} - \dots + (-1)^{n-1} \frac{1}{n} \binom{n}{n} = 1 + \frac{1}{2} + \frac{1}{3} + \dots + \frac{1}{n}.$$

M83. Let p be a prime and let $A = \{1, 2, \dots, p-1\}$. Prove that there is a bijection f from A onto A such that $kf(k) \equiv 1 \pmod{p}$ for each $k \in A$. Hence deduce that if p is an odd prime, then p divides the numerator of $1 + (1/2) + \dots + (1/(p-1))$.

M84. Let p be a prime number. What is the largest power of p that divides $p^2!$?

M85. Show that the 100 digit number $11 \cdots 1$ is divisible by the prime number 101.

M86. Prove that any set of $n^2 + 1$ points in a square with side length one contains two points with distance between them less than or equal to $\frac{\sqrt{2}}{n}$.

M87. Let p and q be prime numbers. If q divides $2^p - 1$ then show that p divides $q - 1$.

M88. If a and b are integers such that 9 divides $a^2 + ab + b^2$ then show that 3 divides both a and b .

M89. Let c be a 3^n digit number whose digits are all equal. Show that 3^n divides c .

M90. Let n be a positive integer and p a prime. Show that the number of ordered basis of a vector space of dimension n over a field of order p is

$$(p^n - 1)(p^n - p)(p^n - p^2) \cdots (p^n - p^{n-1}).$$

Deduce that this number is a multiple of $n!$.

M91. If p is an odd prime, show that

$$\binom{2p-1}{p-1} \equiv 1 \pmod{p^2}.$$

M92. Let X be a set consisting of 5 elements. Let

$$A = \{f : X \rightarrow X; f(f(x)) = x \text{ for each } x \in X\}.$$

Compute the number of elements of A .

M93. Show that, for distinct positive integers m and n , the greatest common divisor of $2^{2^m} + 1$ and $2^{2^n} + 1$ is 1. Deduce that the number of prime integers is infinite.

- M94. Let p be a prime and r an integer, $0 < r < p$. Show that $\frac{(p-1)!}{r!(p-r)!}$ is an integer.
- M95. Show that if a prime number is divided by 30, then the remainder is either one or a prime number.
- M96. Prove that $\sqrt{n-1} + \sqrt{n+1}$ is an irrational number for all positive integers n .
- M97. Show that n^5 and n have the same last digit for all positive integers n .
- M98. Let L and L' be two sets of parallel lines in \mathbf{R}^2 consisting of m and n lines, respectively. Assume that every line in L intersects every line in L' . Find the number of parallelograms formed by the lines in $L \cup L'$.
- M99. A square in the plane is subdivided into n^2 squares S_1, \dots, S_{n^2} of equal size by horizontal and vertical lines. Determine the number of squares in the plane that are unions of a subcollection S_{i_1}, \dots, S_{i_k} .
- M100. For all integers $n \geq 1$, show that $2^{2n} - 3n - 1$ is divisible by 9.
- M101. Find all sets of consecutive natural numbers whose sum is 54.
- M102. Find all the integers n for which $\sqrt{\frac{3n-5}{n+1}}$ is also an integer.
- M103. If 70% of students in a class pass the algebra test, 75% pass the analysis test, 80% pass the geometry test, and 85% pass the number theory test, what is the least percentage of students who pass all four subjects?
- M104. Find the number of elements in the set

$$S = \{(a, b, c) \in \mathbf{N}^3 : a + b + c = 25\},$$

where \mathbf{N} is the set of natural numbers.

M105. Let p, q be distinct odd primes. Prove that the equation $x^2 = 1$ has exactly four (distinct) solutions in the ring of integers modulo pq .

M106. For any $x \in \mathbb{R}$, let $[x]$ be the greatest integer not exceeding x . Let m be a positive integer. Show that

$$[(1 + \sqrt{3})^{2m+1}] = (1 + \sqrt{3})^{m+1} + (1 - \sqrt{3})^{m+1}.$$

M107. Let r be a positive real number. Prove that among the numbers $r, 2r, \dots, (n-1)r$ there is at least one number which differs from an integer by at most $\frac{1}{n}$.

M108. How many of the $n!$ terms in the expansion of a determinant of order n remain, if all the elements of the main diagonal are set to zero ?

M109. Find the divisors between 60 and 65 of $2^{48} - 1$.

M110. Show that every member of the sequence

$$1107, 10017, 100117, \dots$$

is divisible by 53.

M111. There are 102 distinct points in the unit square $[0, 1] \times [0, 1]$. Show that there are at least two distinct points such that the square of the distance between them is at most 0.02.

M112. Let m, n be natural numbers. Show that m and m^{4n+1} have same last digit in their decimal expansions.

M113. Prove that $x^4 - 10x^2 + 1$ is reducible modulo p for every prime p .

M114. Does there exist an integer x satisfying the following congruences?

$$\begin{aligned} 10x &= 1 \pmod{21} \\ 5x &= 2 \pmod{6} \\ 4x &= 1 \pmod{7} \end{aligned}$$

Justify your answer.

M115. Suppose that there are n boxes labelled $1, 2, \dots, n$ and there are n balls also labelled similarly. The balls are thrown into boxes completely randomly so that each box receives one ball.

- How many possible arrangements of balls in boxes is possible?
- Find the probability that the ball labelled 1 goes into the box labelled 1.
- Find the probability that at least one ball is in the box with the same label.

M116. Show that the number of bijections f of $\{1, 2, \dots, n\}$ such that $f(i) \neq i$ for any i is equal to

$$\sum_{j=0}^n (-1)^j \frac{n!}{j!}.$$

M117. Find the smallest integer $n > 0$ such that 2012 divides $9^n - 1$. (Hint: 251 and 503 are prime numbers).

M118. Let p_k be the k -th prime number. Show that there are infinitely many k such that

$$p_{k+1} - p_k > 2.$$

M119. Let S_n denote the group of permutations of $\{1, 2, 3, \dots, n\}$ and let k be an integer between 1 and n . Find the number of elements x in S_n such that the cycle containing 1 in the cycle decomposition of x has length k .

M120. For a real number x , $[x]$ denotes the largest integer less than or equal to x .

- For reals x, y show that $[x + y] - [x] - [y]$ is zero or one.
- For $m \geq 1$ and a prime p , let $\alpha_p(m)$ be the largest power of p which divides m (i.e., $p^{\alpha_p(m)}$ divides m but $p^{\alpha_p(m)+1}$ does not.) It

is known that $\alpha_p(n!) = \sum_{k=1}^{\infty} \left[\frac{n}{p^k} \right]$. Show that $\alpha_p \left(\binom{2n}{n} \right) \leq \frac{\log 2n}{\log p}$.

(HINT: How many terms in the formula for $\alpha_p(n!)$ are non-zero?)

Topology

M121. Let (X, d) be a compact metric space, and $f : X \rightarrow X$ a function such that

$$d(f(x), f(y)) < d(x, y) \text{ for all } x, y \in X, x \neq y.$$

(a) Show that $g(x) = d(x, f(x))$ is a continuous function on X .

(b) Show that there is a point $x_0 \in X$ such that $f(x_0) = x_0$.

M122. Let (X, d) be a metric space. Assume that X is countable and has at least two points. Show that X is not connected.

M123. Let $\epsilon > 0$ be a real number. Let d denote the Euclidean metric on \mathbb{R}^n , the n dimensional real vector space. Show that there cannot exist an uncountable subset S of \mathbb{R}^n such that $d(s, t) > \epsilon$ for all $s \neq t$ in S .

M124. Give an example of a metric space X , a continuous real valued function f on X , and a Cauchy sequence (x_n) in X such that $(f(x_n))$ is not Cauchy.

M125. Let A be a closed subset of the real numbers \mathbb{R} with respect to its usual metric topology. Prove that there exists a countable subset of A whose closure is A .

M126. On the open interval $I = (3, 4)$ define a function f as

$$f(x) = \frac{1}{\min(|x - 3|, |x - 4|)}.$$

Define $d(x, y) = |x - y| + |f(x) - f(y)|$ for $x, y \in I$.

(a) Show that d is a metric.

(b) Show that (I, d) is a complete metric space.

M127. Let f be a continuous map from a topological space X into a Hausdorff space Y . Prove that the graph $\{(x, f(x)) : x \in X\}$ of f is a closed subset of the product space $X \times Y$.

M128. Let X be a compact Hausdorff space. Assume that the vector space of real-valued continuous functions on X is finite dimensional. Show that X is finite.

M129. Let X be a metric space. Assume that, for each positive real number r , the closure of each open ball of radius r is compact. Show that X is complete.

M130. Let (X, d) be a complete metric space, $A_1 \supseteq A_2 \supseteq \dots$ be a sequence of closed sets in X such that $\sup\{d(x, y) : x, y \in A_n\}$ tends to zero as n tends to infinity. Let $f : X \rightarrow X$ be a continuous map. Show that

$$f\left(\bigcap_n A_n\right) = \bigcap_n f(A_n).$$

M131. Let X be a compact metric space. Let $f : X \rightarrow \mathbb{R}$, $g : X \rightarrow \mathbb{R}$ be continuous functions such that $f(x) \neq g(x)$ for all $x \in X$. Show that

$$\inf_x |f(x) - g(x)| > 0.$$

M132. Let X and Y be topological spaces. Consider the following statement:
If X is homeomorphic to a subspace of Y and Y is homeomorphic to a subspace of X then X and Y are homeomorphic.

Is this statement true? Justify your answer.

M133. Let X be a metric space and A, B be disjoint closed subsets of X . If A is compact, show that there exists $\epsilon > 0$ such that $d(a, b) \geq \epsilon$ for all $a \in A, b \in B$.

M134. Let X be an infinite set and let $\{d_n\}_{n \geq 1}$ be a sequence of metrics on X such that $d_n(x, y) \leq 1$ for all $x, y \in X$ and for all $n \geq 1$. Show that

$$d(x, y) = \sum_{n=1}^{\infty} \frac{d_n(x, y)}{2^n}$$

for $x, y \in X$ is a metric on X .

M135. Let $X = [0, \infty)$. Define a metric d on X such that $d(x, y) \leq 1$ for all $x, y \in X$ and such that the topology induced by d is same as the relative real line topology on X .

M136. Let $X = \mathbb{R} \setminus \{0\}$ be equipped with the relative real line topology and let Y denote the curve $Y = \{(x, y) \in \mathbb{R}^2 : xy = 1\}$ with the subspace topology of the usual Euclidean topology on \mathbb{R}^2 . Prove that X is homeomorphic to Y .

M137. Let (X, d) be a metric space and $K \subset X$ be a compact set. Suppose that, for every proper open subset U of X , $U \cap K$ is countable. Show that K is countable.

M138. Show that \mathbb{R} with the metric d defined by :

$$d(x, y) = \left| \frac{1}{1+x^2} - \frac{1}{1+y^2} \right|$$

is not a complete metric space.

M139. Let

$$X = \{ \{ \alpha_n \}_{n \geq 1} : \alpha_n \in \mathbb{R}, \lim_{n \rightarrow \infty} \alpha_n = 0, \sup_n |\alpha_n| \leq 1 \}.$$

Define a metric on X by

$$d(\{ \alpha_n \}_{n \geq 1}, \{ \beta_n \}_{n \geq 1}) = \sup_n |\alpha_n - \beta_n|.$$

Show that (X, d) is not a compact metric space.

M140. Let X be a Hausdorff space. Let $f : X \rightarrow \mathbb{R}$ be such that $\{(x, f(x)) : x \in X\}$ is a compact subset of $X \times \mathbb{R}$. Show that f is continuous.

M141. Show that the set of all rational numbers with the usual topology is not locally compact.

M142. The cofinite topology on \mathbb{R} is the topology in which a subset $F \subseteq \mathbb{R}$ is closed if and only if F is either finite or $F = \mathbb{R}$. Let $X = \mathbb{R}$ with the cofinite topology and $Y = \mathbb{R}$ with the usual topology. Show that any continuous map $f : X \rightarrow Y$ is a constant.

M143. Let $f : (0, 1) \rightarrow \mathbb{R}$ be a continuous function. Show that the graph $G = \{(x, f(x)) : x \in (0, 1)\}$ of f is a non-compact subset of \mathbb{R}^2 .

M144. Show that the complement of a non-empty compact subset of \mathbb{R} is not connected.

M145. Let

$$C = \{(x, y) \in \mathbb{R}^2 \mid x^3 = y^2\}.$$

Prove that \mathbb{R} with its usual topology is homeomorphic to C with its subspace topology induced from \mathbb{R}^2 .

M146. If A is a dense open subset of \mathbb{R} , show that $\mathbb{R} = \{x - y : x, y \in A\}$.

M147. Consider the set

$$A = \{(x, y) \in \mathbb{R}^2 : \text{either } x \notin \mathbb{Q}, \text{ or } y \notin \mathbb{Q}\}.$$

Show that A is path-connected.

M148. Let $A = \{(x, y) \in \mathbb{R}^2 \mid \max\{|x|, |y|\} \leq 1\}$ and $B = \{(0, y) \in \mathbb{R}^2 \mid y \in \mathbb{R}\}$. Show that the set $A + B = \{a + b \mid a \in A, b \in B\}$ is a closed subset of \mathbb{R}^2 .

Sample Question Paper 1
for
GROUP B: Section III. MATHEMATICS (70 marks)

Answer any five questions. All questions carry equal marks.

1. Let A be an $n \times n$ complex matrix, and suppose that $A^n \neq 0$. Prove that $A^k \neq 0$, for all $k \in \mathbb{N}$.
2. Find two non-singular matrices B and C such that

$$BC + CB = 0.$$

3. Let R be a commutative ring with 1 and P be a prime ideal of R . Consider the polynomial ring $R[x]$ and let $P[x]$ be the ideal of $R[x]$ consisting of polynomials whose coefficients all belong to P . Show that the ideal

$$P[x] + \langle x \rangle := \{f(x) + xg(x) : f(x) \in P[x], g(x) \in R[x]\},$$

is a prime ideal of $R[x]$.

4. Fix $n \in \mathbb{N}$. Count the number of functions $h : \{1, 2, 3, \dots, 2n\} \rightarrow \{1, -1\}$ such that

$$\sum_{j=1}^{2n} h(j) > 0.$$

5. Let $q, q' \in \mathbb{N}$ and suppose that q' divides q . Let $U(m)$ denote the multiplicative group of residue classes coprime to m , that is

$$U(m) = (\mathbb{Z}/m\mathbb{Z})^*.$$

Let $\pi : U(q) \rightarrow U(q')$ be such that if $a \in U(q)$, $\pi(a)$ is the unique element in $U(q')$ such that

$$a \equiv \pi(a) \pmod{q'}.$$

Show that π is onto.

6. Let G be a group of order 12. Prove that G has a normal subgroup of order 3 or 4.

7. Define $\phi : \mathbb{N} \rightarrow \mathbb{N}$ by $\phi(m)$ equals the number of elements in

$$\{k : 1 \leq k \leq m, \text{g.c.d.}(k, m) = 1\}.$$

Let $n \in \mathbb{N}$, $n \geq 2$. Show that $\phi(2^n - 1)$ is divisible by n .

8. Prove that $(\mathbb{Q}, +)$ and $(\mathbb{Q} \times \mathbb{Q}, +)$ are not isomorphic as groups.

9. Let X be a compact topological space. Suppose that for any $x, y \in X$ with $x \neq y$, there exist open sets U_x and U_y containing x and y , respectively, such that

$$U_x \cup U_y = X \quad \text{and} \quad U_x \cap U_y = \emptyset.$$

Let $V \subseteq X$ be an open set. Let $x \in V$. Show that there exists a set U which is both open and closed and $x \in U \subseteq V$.

Sample Question Paper 2
for
GROUP B: Section III. MATHEMATICS (70 marks)

Answer any five questions. All questions carry equal marks.

1. Let $\Omega \subset \mathbb{R}^n$ be an open set and $K \subset \Omega$ compact. Prove that there exists an $r > 0$ such that the set

$$\{y \in \mathbb{R}^n : \|y - x\| \leq r \text{ for some } x \in K\}$$

is a compact subset of Ω .

2. Let \sim be an equivalence relation on a topological space X such that each equivalence class is connected and the quotient space X/\sim is connected. Show that X is connected.
3. Let G be a group of order n , H a subgroup of G of order m , $k = \frac{n}{m}$ and S_k the symmetric group on k symbols.
- (a) Show that there is a nontrivial group homomorphism $\phi : G \rightarrow S_k$.
- (b) Assuming $\frac{k!}{2} < n$, show that G has a nontrivial proper normal subgroup.
4. Let G be the multiplicative group of complex numbers of modulus 1 and G_n (n a positive integer) the subgroup consisting of the n -th roots of unity. For positive integers m and n , show that G/G_m and G/G_n are isomorphic groups.
5. Let $A = \mathbb{Q}[X]/(X^3 - 1)$.
- (a) Prove that A is a direct product of two integral domains.
- (b) Is the ring A isomorphic to $\mathbb{Q}[X]/(X^3 + 1)$? Justify your answer.
6. Let X be an $n \times n$ complex matrix of rank 1 and I the $n \times n$ identity matrix. Show that

$$\det(I + X) = 1 + \operatorname{tr}(X),$$

where $\operatorname{tr}(X)$ denotes the trace of X and $\det(X)$ denotes the determinant of X .

7. Let A and X be invertible complex matrices such that $XAX^{-1} = A^2$. Prove that there exists a natural number m such that each eigenvalue of A is an m -th root of unity.
8. For $A = \begin{pmatrix} \frac{2}{3} & \frac{1}{3} \\ \frac{1}{3} & \frac{2}{3} \end{pmatrix}$ and $\vec{v} = \begin{pmatrix} a \\ b \end{pmatrix}$, we define a sequence of vectors $\vec{v}_1 = \vec{v}, \vec{v}_{n+1} = A\vec{v}_n$ for $n \in \mathbb{N}$. Show that $\lim_{n \rightarrow \infty} \vec{v}_n$ exists and is equal to $\begin{pmatrix} \frac{a+b}{2} \\ \frac{a+b}{2} \end{pmatrix}$.
9. Let p_k be the k -th prime number. Show that there are infinitely many k such that

$$p_{k+1} - p_k > 2.$$

PHYSICS

NOTE: This year, the Physics section of Group B of the JRF (CS) afternoon test (CSB) will be modelled on the Physics subsection of Part II of PHB, the afternoon test for JRF (Physics). For more sample questions, candidates may refer to appropriate sections of the samples provided for PHB at <https://www.isical.ac.in/~admission/IsiAdmission2017/PreviousQuestion/Questions-Jrf-Physics.html>

- P1. (a) A particle of mass m moves in a central potential $V(r) = \kappa r^n$, where r is the distance of the particle from the center and κ and n are constants. The particle has a constant angular momentum J . Show that for a circular orbit the radius r_0 satisfies the relation $(r_0)^{n+2} = J^2/(mn\kappa)$.
- (b) Synchronized clocks A and B are at rest in an inertial reference frame. Clock C is moving with velocity $(3/5)c$ along the line joining A and B, c being the velocity of light in vacuum. When C passes A, both the clocks A and C read $t = 0$. Answer the following questions.
- What time does C read when it reaches B?
 - How far apart are A and B in the inertial frame in which clock C is at rest?
 - In C's frame, when A passes C, what time does B read?
- P2. (a) A rocket with mass M_0 and loaded with fuel of mass m_0 takes off vertically upwards in a uniform downward gravitational field. The rocket ejects fuel downwards at velocity U_0 with respect to itself. The fuel is completely ejected in time t_0 . Find the velocity of the rocket at time t_0 in terms of the above parameters and g , acceleration due to gravity.
- (b) Consider two pendulums hanging parallelly from a rigid support, with the bobs connected by a spring with spring constant k . The whole system moves in a plane. Assuming the bobs to have equal mass and each string of length l , show that the system can have at least one mode of frequency matching the normal frequency of each individual pendulum $\sqrt{g/l}$.

- P3. (a) Two positive charges q_1 and q_2 are placed at a distance r apart. A third charge q is placed such that all the three charges are in equilibrium. Find the magnitude and position of charge q .
- (b) Three concentric spherical metallic shells A, B and C of radii a , b and c ($a < b < c$) have surface charge densities σ , $-\sigma$ and σ , respectively. Find the potentials at any point on the circumference for three individual spherical shells.
- (c) Consider a gas of free, non-interacting electrons (each of mass m and charge e) of density n . The gas is in the presence of an electric field $\vec{E}e^{-i\omega t}$ with constant ω . Determine the current induced by the electric field.
- P4. (a) A system of two energy levels E_0 and E_1 ($E_1 > E_0 > 0$) is populated by N particles at temperature T . The particles populate the energy levels according to the classical distribution law.
- (i) Derive an expression for the average energy per particle.
- (ii) Derive an expression for the specific heat of the system of N particles.
- (b) One mole of a monatomic perfect gas initially at temperature T_0 expands (i) at constant temperature and (ii) at constant pressure from volume V_0 to $2V_0$. Calculate the work of expansion and the heat absorbed by the gas in each case.
- P5. (a) A material is brought from temperature T_i to temperature T_f by placing it in contact with a series of N reservoirs at temperature $T_i + \delta T, T_i + 2\delta T, \dots, T_i + N\delta T = T_f$. Assuming that the heat capacity of the material C is temperature independent, calculate the entropy change of the total system, material plus reservoirs. What is the entropy change for $N \rightarrow \infty$ for fixed $T_f - T_i$?
- (b) Derive an expression for the chemical potential of a free electron gas in 3D with a density of N electrons per unit volume at zero temperature ($T = 0$ K). Find the chemical potential, in unit of electron volt, of the conduction electrons (which can be considered as free electrons) in a metal with $N = 10^{22}$ electrons/cm³ at $T = 0$ K. Mass of an electron = 9.11×10^{-31} Kg and Planck's constant = 6.53×10^{-34} J-s.

- P6. (a) Two spin- $\frac{1}{2}$ particles A and B form a composite system. A is in the eigenstate $S_z = +1/2$ and B in the eigenstate $S_x = +1/2$. What is the probability that the total spin of the system will give the value zero?
- (b) Consider a particle with angular momentum j . Then for any simultaneous eigen state of the operators of J^2 and J_z , show that the expectation value satisfies the following relation

$$\langle J_x \rangle = \langle J_y \rangle = 0.$$

- (c) An anharmonic one-dimensional quantum oscillator for a particle of mass m has potential $V(x) = \frac{1}{2}m\omega^2x^2 + \lambda x^4$, where $\lambda > 0$ is small. Using perturbation theory, determine the ground state energy to first order in λ .

- P7. (a) Consider a particle of mass m subject to the potential

$$V(x) = \begin{cases} \infty & \text{for } x < 0 \\ \infty & \text{for } x > L \\ 0 & \text{for } 0 \leq x \leq L. \end{cases}$$

The wave function of the particle at $t = 0$ is given by

$$\psi(x) = \frac{2}{\sqrt{L}} \cos\left(\frac{3\pi x}{L}\right) \sin\left(\frac{4\pi x}{L}\right).$$

- (i) Find the expectation value for energy.
(ii) Find the wave function at $t = T$.
- (b) Consider the following wave function of the simple harmonic oscillator

$$|\phi\rangle = \sum_{n=0}^{\infty} e^{-\frac{1}{2}|\mu|^2} \frac{\mu^n}{\sqrt{n!}} |n\rangle$$

where $|n\rangle$ is an eigen function of the Hamiltonian with eigenvalue $(n + \frac{1}{2})\hbar\omega$ and μ is a complex number. Show that the expectation value of the number operator is given by

$$\langle \phi | \hat{N} | \phi \rangle = |\mu|^2.$$

- P8. (a) Consider the Lagrangian of a charged scalar field $\phi(x)$ with an interaction term $\lambda(\phi^*\phi)^3$. Here λ and m are the coupling constant and mass parameter, respectively.

- (i) Write down the equations of motion.
(ii) Derive an expression for the charge current and show that it is conserved.
- (b) Which of the following reactions violate a conservation law? Where there is a violation, mention the law that is violated.
- (i) $\pi^0 \rightarrow \gamma + \gamma + \gamma$
(ii) $\pi^+ \rightarrow \mu^+ + \nu_\mu$
(iii) $\pi^+ \rightarrow \mu^+ + \bar{\nu}_\mu$

- P9. (a) A particle moves without friction, on the inside of an axially symmetric vessel. The equation of the surface of the vessel is given by,

$$z = \frac{1}{2}b(x^2 + y^2)$$

where b is a constant and z represents the vertical direction, as shown in the figure. The particle is moving in a circular orbit at a constant height $z = z_0$. Obtain the particle's energy and angular momentum in terms of z_0 , b , g , and m where g is the constant acceleration due to gravity and m is the mass of the particle.

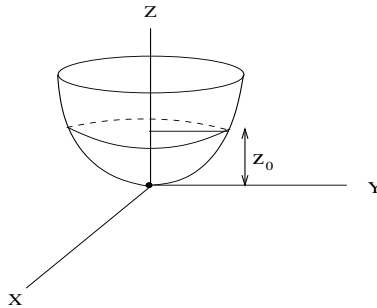

- (b) In an inertial frame, two events have the space time coordinates $\{x_1, y, z, t_1\}$ and $\{x_2, y, z, t_2\}$ where $x_2 - x_1 = 5c(t_2 - t_1)$. Consider another inertial frame which moves along x -axis with velocity u with respect to the first one. Find the value of u for which the events are simultaneous in the latter frame. (c represents the velocity of light in vacuum).

- P10. (a) Consider the Lagrangian,

$$L = e^{2\gamma t} \left(\frac{1}{2} m \dot{q}^2 - \frac{1}{2} m \omega^2 q^2 \right)$$

that represents a damped harmonic oscillator, where p is the momentum conjugate to q and m, ω, γ are constants.

- (i) Using the generating function $F_2(q, p, t) = e^{\gamma t} qP$, write down the Hamiltonian in Q, P co-ordinate system.
 - (ii) Derive the equations of motion in this system.
- (b) A particle of mass m moves in a plane in the field of force given by $\vec{F} = -\hat{r}kr \cos \theta$, where k is a constant and \hat{r} is radial unit vector. Show that $mr^2\dot{\theta} = \text{constant}$.

- P11. (a) A circular loop of wire of radius R , lies in the xy plane, centered at the origin, and carries a current I running counterclockwise as viewed from the positive z -axis.

- (i) What is its magnetic dipole moment?
 - (ii) Evaluate the (approximate) magnetic field at points far from the origin.
 - (iii) Show that for points on the z -axis, your answer in part ii is consistent with the exact field when $z \gg R$.
- (b) Consider a system with charge and current density ρ and \vec{j} in vacuum.
- (i) Write down the Maxwell's equation.
 - (ii) If the signs of all the sources (charge and current density) are reversed what happens to the electric and magnetic field?
 - (iii) If the space is inverted, ($\vec{X} \rightarrow \vec{X}' = -\vec{X}$), what happens to charge and current density and to electric and magnetic field?

- P12. (a) Consider a diatomic crystal where atoms of mass M_1 lie on one set of planes and atoms of mass M_2 lie on planes interleaved between those of the first set. Find the condition of crossing between optical and acoustic branches for any k (k being the wave vector) within 0 to (π/a) .

- (b) The energy levels of a rigid rotor are $\epsilon_j = Aj(j+1)$ where $j = 0, 1, 2, \dots$, and A is a constant. The degeneracy of each level is $g_j = 2j + 1$.

- (i) Find the general expression for the partition function Z using Boltzmann statistics.
- (ii) Show that at high temperature it can be approximated by an integral.
- (iii) Evaluate the high temperature energy and heat capacity C_v .

- P13. (a) 20 litres of gas at atmospheric pressure is compressed isothermally to a volume of 1 litre and then allowed to expand adiabatically to 20 litres.
- (i) Sketch the processes on PV diagram for a monoatomic and a diatomic gas.
 - (ii) For both the cases discuss whether the “net work” - is being done on the system or by the system?
- (b) The speed of longitudinal wave of small amplitude in an ideal gas is

$$v = \sqrt{\frac{dP}{d\rho}}$$

where p is the ambient gas pressure and $\rho(= M/V)$ is the corresponding gas density. Find the speed v of sound in a gas for which the compressions and rarifactions are adiabatic. The symbols have their usual meanings.

- P14. (a) (i) Show that $(\vec{\sigma} \cdot \vec{a})(\vec{\sigma} \cdot \vec{b}) = \vec{a} \cdot \vec{b} + i\vec{\sigma} \cdot (\vec{a} \times \vec{b})$ where \vec{a} and \vec{b} are two vectors in \mathfrak{R}^3 , and σ_x , σ_y and σ_z are usual Pauli spin matrices.
- (ii) Consider the Dirac Hamiltonian of a free particle

$$H = c\vec{\alpha} \cdot \vec{p} + \beta mc^2.$$

Show that $\left(\vec{L} + \frac{1}{2}\hbar\vec{\sigma}\right)$ commutes with the Hamiltonian H .

Here \vec{L} is the orbital angular momentum and other symbols have their usual meanings.

- (b) Find the magnetic moment, in units of Bohr magneton, of an atom in the state 3P_2 . In how many sub-states will the state split, if the atom is put in a weak magnetic field? Draw the splitting diagram.

- P15. (a) A particle in the infinite square well of width a has the initial wave function

$$\psi(x, 0) = A \sin^3(\pi x/a), \quad 0 \leq x \leq a$$

- (i) Find the normalization constant A .
 - (ii) Determine the wave function $\psi(x, t)$ at a later time t .
 - (iii) Calculate the expectation value of x as a function of time.
- (b) The wave function of the harmonic oscillator at $t = 0$ is given by

$$\psi(0) = N (|0\rangle + 2|1\rangle)$$

where N is the normalization constant and $|n\rangle$ is the eigenfunction of corresponding energy eigenvalue $E_n = \hbar\omega \left(n + \frac{1}{2}\right)$. Calculate the minimum time in which the wave function evolves to its orthogonal state.

- P16. (a) Consider a complex scalar field ϕ having mass m .
- (i) Find the equations of motion.
 - (ii) Find the Noether charge current.
 - (iii) Now introduce a self-interaction term that is of fourth power in the complex scalar field and find the Noether charge current in this case also.
- (b) Give reasons for why the reactions below are not allowed (the symbols have their usual meanings). Attempt any four.
- (i) $p \rightarrow e^+ + \pi^0$
 - (ii) $p + n \rightarrow p + \Lambda^0$
 - (iii) $K^- \rightarrow \pi^0 + e^-$
 - (iv) $K^+ \rightarrow \pi^+ + \pi^+ + \pi^0$
 - (v) $n \rightarrow p + \pi^-$
 - (vi) $p \rightarrow e^+ + n + \nu_e$
 - (vii) $p + \bar{p} \rightarrow \gamma$

- P17. (a) A particle of mass m is sliding on a smooth surface along a path that satisfies $r^2 = az$ where a is a constant. Using cylindrical coordinates r, ϕ, z where $x = r \cos \phi, y = r \sin \phi, z = z$:
- (i) Set up the Lagrangian and find the equations of motion.
 - (ii) Identify the cyclic coordinate.

- (b) In a non-relativistic system, a charged pion (with charge $+q$ for π^+ or $-q$ for π^-) has kinetic energy T and it is moving towards a massive target nucleus with charge Q . The pion is considered to hit the nucleus if its distance is b from the nucleus (see figure). The collision cross-section is given by $\Sigma = \pi d^2$, where d is the impact parameter. Show that the cross-sections, Σ^+ and Σ^- for

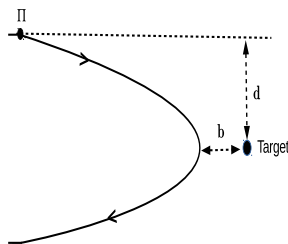

π^+ and π^- respectively are given by

$$\Sigma^+ = \frac{\pi b^2(T - V)}{T}, \quad \Sigma^- = \frac{\pi b^2(T + V)}{T}$$

where $V = \frac{qQ}{b}$ is the Coulomb potential. (Impact parameter d is defined as the length of the perpendicular drawn from the target (nucleus) to the line of motion that the pion would have taken if there was no interaction.)

- P18. (a) A particle of mass m is placed in a finite spherical well of radius a with the following potential:

$$V(r) = \begin{cases} -V_0 & \text{if } r \leq a \\ 0 & \text{if } r > a \end{cases}$$

- (i) Solving the radial equation with $\ell = 0$ find the ground state wave function.
(ii) Show that there is no bound state if

$$V_0 < \frac{\pi^2 \hbar^2}{8ma^2}$$

- (b) The Hamiltonian for a spin- $\frac{1}{2}$ particle of mass m with charge $+e$ in an external magnetic field \vec{B} is

$$H = -\frac{ge}{2mc} \vec{s} \cdot \vec{B}$$

where the symbols have their usual meaning.

- (i) Derive the expression for $\frac{d\vec{s}}{dt}$.
 (ii) Assuming $\vec{B} = B\hat{y}$, find $s_z(t)$ in terms of the given quantities.
- P19. (a) Two synchronized clocks A and B are at rest in an inertial reference frame. The distance between them is L . Another clock X is moving with a velocity $\frac{3}{5}c$ along the line joining A and B , c being the velocity of light in vacuum. Both the clocks A and X read zero when X passes A . When X reaches the mid point of the line joining A and B , what are the readings of clocks A and B with respect to the inertial frame attached with X ?
- (b) Consider the following state of a quantum harmonic oscillator

$$|\psi\rangle = c_0|0\rangle + c_k|k\rangle$$

where $|0\rangle$ and $|k\rangle$ are the energy eigenstates. The non-zero real coefficients c_0 and c_k satisfy $c_0^2 + c_k^2 = 1$. Find the allowed values of k for which

$$\langle\psi|\frac{1}{2}m\omega^2\hat{x}^2|\psi\rangle = \langle\psi|\frac{\hat{p}^2}{2m}|\psi\rangle$$

where the symbols have their usual meaning.

- P20. (a) A square frame with side a and a long wire carrying a current I are located in the same plane as shown in the figure below. The frame translates to the right with a constant velocity v . Find the e.m.f. induced in the frame as a function of x .
- (b) Suppose there are two parallel plate electrodes of area A , at voltages 0 and V_0 respectively, separated by a distance d (see the figure below). The dimensions of the plates are much larger than the separation between them. With an unlimited supply of electrons at rest to the lower potential electrode (placed at $x = 0$), a steady current I flows between the plates.
- (i) Write the Poisson's equation for the region between the plates.

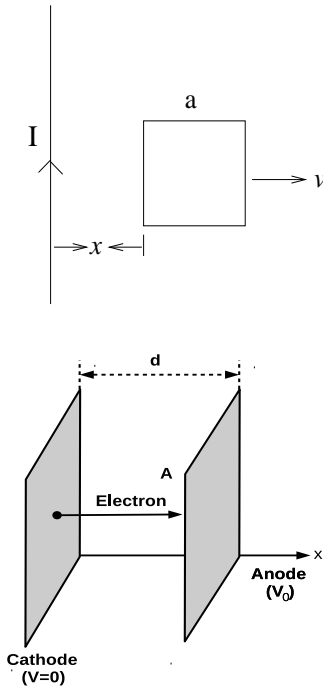

- (ii) What is the speed of the electrons at point x , where the potential is $V(x)$?
- (iii) Show that $\frac{d^2V}{dx^2} = \beta V^{-1/2}$ and find the constant β .

- P21. (a) A system with two degrees of freedom is described by the Hamiltonian

$$H = q_1 p_1 - q_2 p_2 - a q_1^2 + b q_2^2$$

where q_i, p_j obey canonical Poisson brackets and a, b are numerical constants. Show that

$$F_1 = \frac{p_1 - a q_1}{q_2}, \quad F_2 = q_1 q_2$$

are constants of motion.

- (b) A K -meson of rest energy 494 MeV decays into a muon of rest energy 106 MeV and a neutrino of zero rest energy. Find the kinetic energies of muon and neutrino in the rest frame of K -meson in which K -meson decays at rest.

- (c) State the conservation laws that are violated for the following processes:
- (i) $\nu_\mu + n \longrightarrow e^- + p$
 - (ii) $p + \bar{p} \longrightarrow \Lambda^0 + \Lambda^0$
- P22. (a) Suppose the density of states of a free electron gas in three dimensions gets increased by eight times.
- (i) Explain on physical grounds whether the Fermi temperature of the system increases or decreases.
 - (ii) Find out the factor by which it increases or decreases.
- (b) Consider a system of N non-interacting spins each with a magnetic moment of magnitude μ . The system is placed in an external uniform magnetic field \vec{B} .
- (i) Write down the Hamiltonian of the system
 - (ii) Calculate the magnetization per spin at temperature T .
- P23. Consider a one-dimensional tight-binding periodic lattice with lattice constant a , on-site energy ϵ and nearest-neighbor hopping strength t .
- (a) Determine the energy dispersion (viz, $E-k$) relation.
 - (b) Find the wave vector k in terms of lattice constant and total number of lattice sites for an N -site lattice under periodic and finite boundary conditions.
 - (c) Calculate the energy band width for the periodic case.
- P24. (a) Consider a free scalar field.
- (i) Derive an expression for the Hamiltonian in terms of creation and annihilation operators.
 - (ii) What is the energy of the vacuum?
- (b) Consider a field theory where a Dirac electron ψ interacts with a charged scalar ϕ and a neutral η .
- (i) Give examples of simplest possible interaction terms in both cases, maintaining gauge invariance.
 - (ii) Draw Feynman diagrams for the processes $\psi^- \phi^+ \longrightarrow \psi^- \phi^+$ and $\psi^- \eta \longrightarrow \psi^- \eta$.

STATISTICS

NOTE: This year, the Statistics section of Group B of the JRF (CS) afternoon test (CSB) will be modelled on the JRF (Statistics) afternoon test (STB) papers. This section is expected to have about 8 questions; candidates will be expected to attempt about 5 questions from this section (in addition to questions from Group A). All questions from Group B will carry equal marks.

For more sample questions, candidates may refer to the samples provided for STB at <http://www.isical.ac.in/~deanweb/JRFSTATSQ.html>.

- S1. Consider a random arrangement of 20 boys and 16 girls in a line. Let X be the number of boys with girls on both sides, and Y be the number of girls with boys on both sides. Find $E(X + Y)$.
- S2. Let X_1, \dots, X_n be independently and identically distributed random variables with distribution function F , where n is an odd integer. Let Y_1, \dots, Y_n be independently and identically distributed observations from the empirical distribution function \hat{F}_n associated with X_1, \dots, X_n . Obtain the distribution of the median of Y_1, \dots, Y_n .
- S3. Let X be a nonnegative random variable such that

$$E\left(\sum_{n=1}^{\infty} X^n\right) < \infty. \quad (*)$$

- (a) Show that X cannot be uniformly distributed over $(0, 1)$.
- (b) Show that $P(X \geq 1) = 0$.
- (c) Give an example of a continuous random variable X satisfying the relation in (*).
- S4. A shopkeeper places an order of one extra item only when his stock of that item at the end of a week is one or less. Let X_n , $n \geq 1$, denote the number of items in his stock at the end of the n -th week before he decides to place an order or not, with $X_0 = 0$. Assume that the weekly demand for the sale of this item from this shop follows a Poisson distribution with mean λ , and the item is sold on demand till the stock lasts.

Prove that X_n , $n \geq 1$, defines a Markov chain, and then specify its state space and the transition probability matrix. Also derive the stationary probabilities.

- S5. Let $(X_1, Y_1), \dots, (X_n, Y_n)$ be independently and identically distributed observations from the uniform distribution over the triangle ABC , where $A = (0, 0)$, $B = (a, 0)$, $C = (a, b)$, and a, b are unknown positive constants. Define $(U_i, V_i) = (X_i, Y_i/X_i)$. Show that, for each $i = 1, \dots, n$, the random variable U_i is independent of V_i . Hence or otherwise, find the maximum likelihood estimator of the area of the triangle ABC .
- S6. Let $Y = e^{UX} + Z$, where U, X, Z are independent. Here X is uniformly distributed over $(0, 1)$, Z has the standard normal distribution and U has density $f(u) = 2u$, for $0 < u < 1$.
- Find the best predictor of Y given $X = \frac{1}{2}$ when U and Z are unknown.
 - Find the best *linear* predictor of Y given $X = \frac{1}{2}$ when U and Z are unknown.
- S7. Suppose that you have a random observation X with density f over the real line. Based on X , we want to test
- $$H_0 : f(x) = \frac{1}{\sqrt{2\pi}} e^{-x^2/2} \text{ versus } H_1 : f(x) = \frac{1}{\pi(1+x^2)}.$$
- Prove that a test which rejects H_0 if and only if $|X| > \Phi^{-1}(0.975)$ is a most powerful test of level $\alpha = 0.05$ for this problem. Here $\Phi(x)$ is the standard normal distribution function.
 - Find the power of the test described in part (a) above.
- S8. Consider a completely randomised design (CRD) with t treatments, $t \geq 2$, and $n = 4t + 3$ observations. If we want to minimise the average variance of the best linear unbiased estimators (BLUES) of all the pairwise comparisons of treatment effects, how many observations should be allocated to each treatment?

- S9. Consider a Markov chain $\{X_n : n \geq 0\}$ with state space $S = \{0, 1, 2, 3\}$ and stationary transition probability matrix $P = ((p_{ij}))$ satisfying

$$\sum_{j=0}^3 j p_{ij} = i \quad \text{for } i = 0, 1, 2, 3.$$

Show that 0 and 3 must be absorbing states.

- S10. Suppose that (X_i, Y_i) , $i \geq 1$, are independent and identically distributed bivariate random vectors with $E(X_1) = \mu_x$, $E(Y_1) = \mu_y$, $Var(X_1) = \sigma_x^2$, $Var(Y_1) = \sigma_y^2$ and $Corr(X_1, Y_1) = \rho_{xy}$. If X_1 and Y_1 are positive random variables, show that

$$Z_n = \sqrt{n} \left(\frac{\sum_{i=1}^n X_i}{\sum_{i=1}^n Y_i} - \frac{\mu_x}{\mu_y} \right)$$

converges in distribution to a normal random variable with mean 0 and variance $\frac{1}{\mu_y^4}(\mu_y^2 \sigma_x^2 + \mu_x^2 \sigma_y^2 - 2\rho_{xy} \mu_x \mu_y \sigma_x \sigma_y)$.

- S11. Consider a sequence of random variables $\{X_n : n \geq 1\}$, where $X_n \sim N(0, n^{-\alpha})$ for $n = 1, 2, \dots$ and $\alpha > 0$ is fixed. Show that X_n converges almost surely to 0.
- S12. Let X_1, X_2, \dots, X_n be independent Bernoulli random variables with $P(X_i = 1) = p$ for $i = 1, 2, \dots, n$, where $p \in [1/2, 1)$.
- Is $T = n^{-1} \sum_{i=1}^n X_i$ a minimum variance unbiased estimator of p ? Justify your answer.
 - Show that there exists an estimator T_0 such that $E(T - p)^2 > E(T_0 - p)^2$ for all $p \in [1/2, 1)$.
- S13. Let X_1, X_2, \dots, X_n be independent and identically distributed normal variables with mean θ and variance 1. For the testing problem $H_0 : \theta = 0$ against $H_1 : \theta = 1$, find the critical region that minimizes $P(\text{Type I Error}) + 3 P(\text{Type II Error})$.

S14. Consider the following data set

x	1	2	3	4	5	6
y	18.6	15.0	10.6	7.2	3.4	-1.1

Find the equation of the line $y = \alpha + \beta x$ that passes through the point (5, 3) and minimizes $\sum_{i=1}^6 |y_i - \alpha - \beta x_i|$, where (x_i, y_i) denotes the i -th ($i = 1, 2, \dots, 6$) observation.

S15. Consider the following block design D with 3 treatments denoted by 1, 2 and 3, arranged in 3 blocks, each of size 5.

$$D = \begin{bmatrix} 1 & 2 & 3 & 1 & 2 \\ 1 & 2 & 3 & 2 & 3 \\ 1 & 2 & 3 & 3 & 1 \end{bmatrix}$$

- Identify a set of maximum number of linearly independent estimable functions of the treatment effects under the usual fixed effects additive two way ANOVA model.
- Find the best linear unbiased estimator of $\tau_1 - \tau_2$, where τ_i denotes the i -th ($i = 1, 2, 3$) treatment effect.

S16. Let θ be the unknown proportion of tax evaders (denoted by attribute A) in a finite population of size N . In order to estimate θ , a statistician chose a sample of size n using simple random sampling without replacement. Because of the sensitive nature of A, a fair die was used. Two faces of the die were inscribed with A and the other four faces were inscribed with A^c . Each person in the sample was asked to roll the die till s/he got the face showing her/his true state and only report Z , the number of rolls required for it. These responses were denoted by Z_1, Z_2, \dots, Z_n . Find

- an unbiased estimator T for θ ,
- an unbiased estimator for $\text{Var}(T)$.

S17. Let $S = \{(x, y) \in \mathbb{R}^2 : x^2 + y^2 < 1\}$ be the unit circle in \mathbb{R}^2 . Let $(X_1, Y_1), (X_2, Y_2)$ be independent, both having uniform distribution over S . Let D denote the Euclidean distance between (X_1, Y_1) and (X_2, Y_2) . Show that $E(D^2) = 1$.

S18. Let X_1, \dots, X_n be independent $N(0,1)$ variables and let

$$U_n = \frac{X_1 + \dots + X_n}{X_1^3 + \dots + X_n^3}.$$

Show that U_n converges in distribution to $a + bU$ where $a, b \in \mathbb{R}$ and U is a standard Cauchy random variable.

S19. Suppose X_1, \dots, X_n are independent $N(0,1)$ variables. Let $2 \leq m < n$. Let S_m^2 and S_n^2 be given by $S_m^2 \stackrel{def}{=} \sum_{i=1}^m (X_i - \bar{X}_m)^2$ and $S_n^2 \stackrel{def}{=} \sum_{i=1}^n (X_i - \bar{X}_n)^2$, respectively, where $\bar{X}_m \stackrel{def}{=} \sum_{i=1}^m X_i/m$ and $\bar{X}_n \stackrel{def}{=} \sum_{i=1}^n X_i/n$. Let $T = S_n^2 - S_m^2$. Show that $T \sim \chi_{n-m}^2$.

S20. Let X_1, \dots, X_n be a random sample of size n from a uniform distribution on $(0,1)$. Let $X_{(1)} < X_{(2)} < \dots < X_{(n)}$ be the corresponding order statistics. Define

$$R(X_1) = r \text{ if } X_{(r)} = X_1, \quad r = 1, 2, \dots, n.$$

Find the correlation coefficient between X_1 and $R(X_1)$.

S21. Let $X \sim N(\theta, 1)$. Let $Y_i = Z_i + X$, where $Z_i, i = 1, \dots, n$ are independent $N(0,1)$ variables and Z_1, Z_2, \dots, Z_n are independent of X . Suppose Y_1, \dots, Y_n are observed. Is $\bar{Y} = \sum_{i=1}^n Y_i/n$ sufficient for θ ? Justify.

S22. Suppose $\theta \sim \text{Uniform}\{1, 2, \dots, N\}$ and the conditional distribution of U given θ is $\text{Uniform}\{1, 2, \dots, \theta\}$. Based on the observation U , find the predictor of θ with minimum Mean Squared Error.

S23. Suppose we observe the random variable X that has a density

$$f(x) = \begin{cases} 2(1-\theta)x + \theta & \text{if } 0 \leq x \leq 1 \\ 0 & \text{otherwise.} \end{cases}$$

where $0 \leq \theta \leq 2$ and θ is unknown. Find the Uniformly Most Powerful test for $H_0 : \theta \leq \frac{1}{2}$ vs. $H_1 : \theta > \frac{1}{2}$ based on X .

S24. A 2^5 factorial experiment with factors A, B, C, D, E, is conducted in 4 blocks each of size 8. Four of the treatment combinations in the principal block are : ab, acd, de, bce .

- (a) What will be the remaining treatment combinations in the principal block?
 (b) Identify the confounded effects.

S25. A block design with 8 treatments $1, \dots, 8$, is planned with the following 10 blocks:

Block No.	Treatments	Block No.	Treatments
1	1, 2, 5	6	3, 4, 8
2	3, 7	7	4, 8
3	7, 8, 8	8	2, 5
4	5, 6	9	1, 5, 6
5	3, 3, 7	10	7, 8

Let τ_i denote the effect of treatment i , $i = 1, \dots, 8$.

- (a) Are the following contrasts estimable: $\tau_1 - \tau_2$, $\tau_2 - \tau_6$, $\tau_5 - 2\tau_7 + \tau_8$, $2\tau_3 - \tau_7 - \tau_8$?
 (b) What is the rank of the C-matrix of this design?

S26. Suppose that X_1, X_2, \dots are independent and identically distributed $N(0, 1)$ random variables. Let

$$Y_i = \begin{cases} X_i - 1 & \text{if } X_i \leq 0, \\ X_i & \text{if } X_i > 0, \end{cases} \quad i = 1, 2, \dots$$

- (a) Find the mean and variance of Y_1 .
 (b) Find constants α_n and β_n , depending on n , such that

$$\alpha_n \sum_{i=1}^n Y_i - \beta_n \text{ converges in distribution to } Z \text{ as } n \rightarrow \infty,$$

where Z has a standard normal distribution.

S27. Let X_1, X_2, \dots, X_n be independent and identically distributed random variables with one of two probability density functions $f(x|\theta)$, $\theta = 0, 1$. If $\theta = 0$, then

$$f(x|\theta) = \begin{cases} 1 & \text{if } 0 < x < 1, \\ 0 & \text{otherwise,} \end{cases}$$

while if $\theta = 1$, then

$$f(x|\theta) = \begin{cases} \frac{1}{2\sqrt{x}} & \text{if } 0 < x < 1, \\ 0 & \text{otherwise.} \end{cases}$$

- (a) Find the maximum likelihood estimator $\hat{\theta}_n$ of θ .
 (b) Show that $\lim_{n \rightarrow \infty} P_{\theta=0}(\hat{\theta}_n = 0) = 1$.

S28. Let X_1, X_2, \dots, X_n ($n \geq 2$) be independent and identically distributed random variables having uniform distribution over $\{1, 2, \dots, \theta\}$, where $\theta \in \{1, 2, \dots\}$.

- (a) Let $X_{(n)} = \max(X_1, \dots, X_n)$. Show that $X_{(n)}$ is sufficient for θ .
 (b) We wish to test the hypothesis $H_0 : \theta \leq \theta_0$ against $H_1 : \theta > \theta_0$, where θ_0 is a known positive integer. For $0 < \alpha < 1$, consider the test

$$T(X_{(n)}) = \begin{cases} 1 & \text{if } X_{(n)} > \theta_0, \\ \alpha & \text{otherwise.} \end{cases}$$

Show that T is a uniformly most powerful test of size α for testing H_0 against H_1 .

S29. Consider an urn containing 10 red balls, 10 white balls, and 10 black balls. Balls are drawn at random with replacement one by one. Let T be the minimum number of draws required to get balls of three colours. Find the distribution of T .

S30. Let $\{X_n : n \geq 1\}$ be a sequence of independent and identically distributed random variables, each having an exponential distribution with mean 1. Let $M_n = \max\{X_k : 1 \leq k \leq n\}$. Show that

$$\frac{M_n}{\log n} \xrightarrow{p} 1 \text{ as } n \rightarrow \infty.$$

S31. Consider the multiple linear regression model (with n subjects and p predictors) $\mathbf{y} = \mathbf{X}\boldsymbol{\beta} + \boldsymbol{\epsilon}$, where $\boldsymbol{\epsilon} \sim N_n(\mathbf{0}, \sigma^2 \mathbf{I}_n)$.

- (a) Assume $\text{rank}(\mathbf{X}) = p$. Obtain the uniformly minimum variance unbiased estimator of σ^2 .
 (b) Suppose p is a fixed positive integer. Show that the estimator in (a) is a consistent estimator of σ^2 .
 (c) Suppose now that both n and p vary such that $n - p \rightarrow \infty$. Show that the estimator in (a) is a consistent estimator of σ^2 .

S32. Consider a population $U = \{1, 2, 3\}$ of size 3. Let Y be a variable taking value Y_i on unit i , $i = 1, 2, 3$. The population mean is $\bar{Y} = (Y_1 + Y_2 + Y_3)/3$. A sample of size 2 is drawn from U by using simple random sampling *without* replacement. Let T be the sample mean. Consider the following estimator:

$$T^* = \begin{cases} \frac{1}{2}Y_1 + \frac{1}{2}Y_2 & \text{if units 1 and 2 are selected,} \\ \frac{1}{2}Y_1 + \frac{2}{3}Y_3 & \text{if units 1 and 3 are selected,} \\ \frac{1}{2}Y_2 + \frac{1}{3}Y_3 & \text{if units 2 and 3 are selected.} \end{cases}$$

- (a) Prove that T^* is an unbiased estimator of \bar{Y} .
 (b) Show that $\text{Var}(T^*) < \text{Var}(T)$ if $Y_3(3Y_2 - 3Y_1 - Y_3) > 0$.

S33. Consider the Laplace distribution with probability density function $f(x|\theta)$ given by

$$f(x|\theta) = \frac{1}{2} \exp(-|x - \theta|), \quad x \in \mathbb{R}, \quad \theta \in \mathbb{R}.$$

Prove that the family $\{f(x|\theta) : \theta \in \mathbb{R}\}$ is *not* a one-parameter exponential family.

S34. (a) Suppose $X \sim N(0, 1)$. Let $0 < a < b$. We define

$$Y = \begin{cases} X & \text{if } a < |X| < b, \\ -X & \text{otherwise.} \end{cases}$$

Find the distribution of Y .

(b) Suppose X is a non-negative integer-valued random variable such that

$$P(X = k + 1) = \frac{6 + k}{3k + 1} P(X = k) \text{ for } k = 0, 1, 2, \dots,$$

and $P(X = 0) = 1/4$. Find $E(X)$.

- S35. (a) Let X_1, X_2, \dots be independent and identically distributed random variables with

$$P(X_1 = 1) = p, \quad P(X_1 = -1) = 1 - p, \quad 0 < p < 1.$$

Define Y_1, Y_2, \dots as follows:

$$Y_n = \begin{cases} 1 & \text{if } X_n = 1 \text{ and } X_{n+1} = 1, \\ 0 & \text{otherwise.} \end{cases}$$

Show that $(Y_1 + \dots + Y_n)/n \xrightarrow{p} p^2$.

- (b) Suppose an urn contains w white balls, b black balls, and r red balls; $w, b, r > 0$. Balls are drawn one by one without replacement and at random until all balls are exhausted. Find the probability that, among the three colours, the white balls are exhausted first.

- S36. A person has four umbrellas, some at his home and the remaining at his office. Every time he goes from one of these locations to the other, he will carry an umbrella if it rains and if an umbrella is available at the location he starts from. Assume that every time he starts from one location for the other, it may rain with probability p ($0 < p < 1$), independently of the occurrence of rainfall at other times. Let X_n denote the number of umbrellas at his office on his n -th visit to the office.

- (a) Viewing $\{X_n\}$ as a Markov chain, describe the state space and write down the transition matrix.
 (b) Taking $p = 1/2$, find the stationary distribution of this chain.

- S37. (a) Let X_1, \dots, X_n be independent and identically distributed (iid) according to the logistic distribution with cumulative distribution function

$$F_\theta(x) = \frac{1}{1 + e^{-(x-\theta)}}, \quad -\infty < x < \infty, \quad -\infty < \theta < \infty.$$

Show that the likelihood equation has a unique root $\hat{\theta}_n$ that maximizes the likelihood function.

- (b) Let X_1, \dots, X_n be iid according to the truncated Poisson distribution with probability mass function given by

$$p(x, \theta) = \frac{e^{-\theta} \theta^x}{x!(1 - e^{-\theta})}, \quad x = 1, 2, \dots; \quad \theta > 0.$$

Does the maximum likelihood estimator of θ exist when $X_1 = \dots = X_n = 1$? Give reasons.

- S38. Let C be a circle in the X - Y plane, with centre at (θ, θ) and radius r . Let the points $(X_1, Y_1), (X_2, Y_2), \dots, (X_n, Y_n)$ be independently drawn at random from the interior of C .

- (a) Consider estimators of θ which are of the form

$$T = \sum_{i=1}^n (a_i X_i + b_i Y_i).$$

Find a_1, \dots, a_n and b_1, \dots, b_n that minimize $E(T - \theta)^2$.

- (b) Obtain a consistent estimator of r . Justify your answer.

- S39. (a) Let $\mathbf{X} = (X_1, \dots, X_n)$ be a random sample from the discrete uniform distribution on points $\{1, \dots, \theta\}$, where $\theta \in \mathbb{N} =$ the set of natural numbers. Consider the problem of testing $H_0 : \theta \leq 5$ versus $H_1 : \theta > 5$. Let $0 < \alpha < 1/2$. Show that

$$\phi^*(\mathbf{X}) = \begin{cases} 1 & \text{if } X_{(n)} > 5, \\ \alpha & \text{if } X_{(n)} \leq 5, \end{cases}$$

where $X_{(n)} \stackrel{def}{=} \max(X_1, \dots, X_n)$, is a uniformly most powerful (UMP) test of size α .

- (b) Suppose $\{F_\theta : \theta \in \Theta\}$ is a parametric model, where $\Theta \subseteq \mathbb{R}$ is an open set. Let X_1, \dots, X_n be independent and identically distributed observations from F_θ . Suppose $T(X_1, \dots, X_n)$ is an estimator of a parametric function $\tau(\theta)$ of θ such that T is unbiased and attains the Cramer-Rao lower bound. Show that $T(X_1, \dots, X_n) = \tau(\hat{\theta}_n)$, where $\hat{\theta}_n$ is the maximum likelihood estimator of θ based on X_1, \dots, X_n .

S40. Let $\mathbf{X}_1, \dots, \mathbf{X}_n$ be independent and identically distributed observations from a $N_3(\boldsymbol{\mu}_0, \boldsymbol{\Sigma})$ distribution, where both $\boldsymbol{\mu}_0$ and $\boldsymbol{\Sigma}$ are unknown, and $\boldsymbol{\Sigma}$ is known to be positive definite. Assume $n \geq 4$. Suppose \mathbf{Y} is another observation, independent of all the \mathbf{X}_i 's, from a $N_3(\boldsymbol{\mu}_1, \boldsymbol{\Sigma})$ distribution, where $\boldsymbol{\mu}_1$ is unknown.

- Based on $\mathbf{X}_1, \dots, \mathbf{X}_n$ and \mathbf{Y} , obtain the likelihood ratio test statistic λ for $H_0 : \boldsymbol{\mu}_0 = \boldsymbol{\mu}_1$ versus $H_1 : H_0 \text{ is false}$.
- Find a statistic T , having a Hotelling's T^2 distribution as its null distribution, such that $-2 \log \lambda$ is a monotonically increasing function of T .

S41. Let $\mathbf{w} = (w_1, \dots, w_n)^T$ be a known vector of unit length and $\boldsymbol{\theta} = (\theta_1, \dots, \theta_n)^T$ be an unknown parametric vector. Also, let $\mathbf{Y} = (Y_1, \dots, Y_n)^T$ be a random vector such that $E(Y_i) = \theta_i - w_i(\mathbf{w}^T \boldsymbol{\theta})$, $i = 1, \dots, n$. Moreover, we assume that Y_1, \dots, Y_n are uncorrelated with a common unknown variance σ^2 . (Here $\mathbf{a}^T \mathbf{b}$ represents the scalar product of the vectors \mathbf{a} and \mathbf{b} .)

- Obtain a necessary and sufficient condition on vector \mathbf{b} for the linear parametric function $\mathbf{b}^T \boldsymbol{\theta}$ to have an unbiased estimator of the form $\mathbf{u}^T \mathbf{Y}$.
- Find a nonnegative definite matrix \mathbf{Q} such that $\mathbf{Y}^T \mathbf{Q} \mathbf{Y}$ is an unbiased estimator of σ^2 .
- Does (b) above have a unique answer? Justify.

S42. Consider a finite population $U = \{1, 2, \dots, N\}$ of size N . Let y be a study variable taking value y_i on unit i , $1 \leq i \leq N$. We want to estimate the population mean $\bar{Y} = \frac{1}{N} \sum_{i=1}^N y_i$. Let x be an auxiliary variable taking value x_i on unit i , $1 \leq i \leq N$. We assume that $x_i > 0$ is known for all units i , $1 \leq i \leq N$.

For a sample s , let $n(s)$ denote the number of units in s . A sample s of size n is selected from the population U of using the following sampling design p :

$$p(s) = \frac{\sum_{i \in s} x_i}{\binom{N-1}{n-1} \sum_{i=1}^N x_i} \quad \text{if } n(s) = n,$$

$$= 0 \quad \text{otherwise.}$$

To estimate the population mean $\bar{Y} = \frac{1}{N} \sum_{i=1}^N y_i$, it is decided to use the estimator \widehat{Y}_R given by

$$\widehat{Y}_R = \frac{\sum_{i \in s} y_i}{\sum_{i \in s} x_i} \bar{X}, \text{ where } \bar{X} = \frac{1}{N} \sum_{i=1}^N x_i.$$

Suppose we express the mean squared error $E\left(\widehat{Y}_R - \bar{Y}\right)^2$ of \widehat{Y}_R as $\mathbf{y}^T \mathbf{A} \mathbf{y}$, where $\mathbf{y}^T = (y_1, y_2, \dots, y_N)$, and $\mathbf{A} = ((a_{ij}))$ is an $N \times N$ matrix of coefficients a_{ij} that do not depend on \mathbf{y} .

Show that the following statements are true.

- (a) p is indeed a sampling design.
- (b) \widehat{Y}_R is unbiased for \bar{Y} under the design p .
- (c) $\mathbf{A} \mathbf{x} = \mathbf{0}$, where $\mathbf{x}^T = (x_1, x_2, \dots, x_N)$ is the vector of auxiliary variable values and $\mathbf{0}$ is the vector of all zeroes.